

Hawai'i Energy

Solar Water Heating Program Handbook

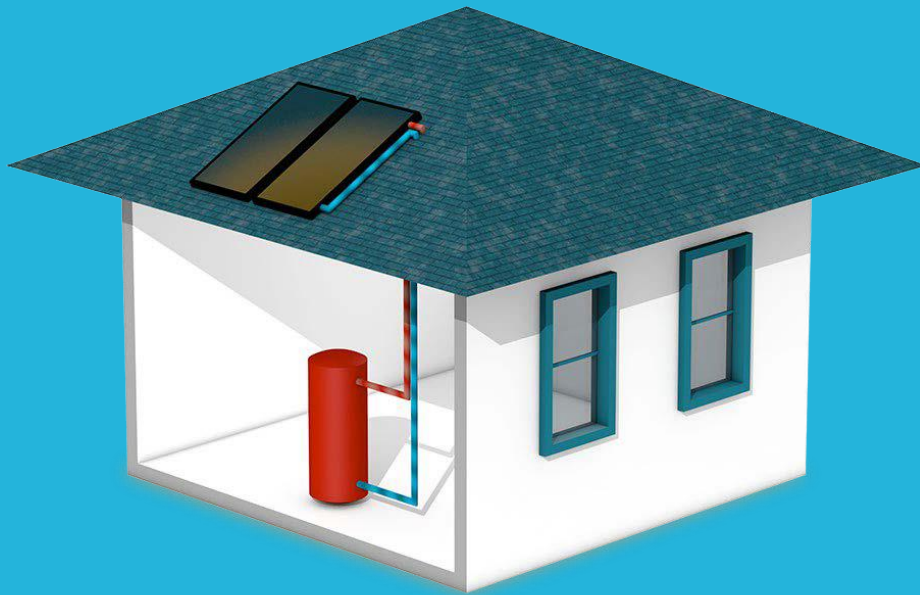

Design Guidelines

EFFECTIVE JANUARY 2024



**THIS HANDBOOK IS EFFECTIVE
FOR: PROGRAM YEAR 2024**



Table of Contents

Preface 1

Standards & Specifications 2

Part I– General 2

Part II PRODUCTS..... 10

3 Part III – Execution Guidelines 18

4 Residential Solar Water Heating Tables..... 25

5 Collector Orientation Factor Compass..... 33

6 Plumbing Layout Figures..... 33

7 Basic SWH System Sizing Equations..... 37

8 Form 1 - Residential System Verification Form 39

9 System Inspection Checklist..... 40

10 Blazing Tubes Inspection Checklist 41

11 Accepted Products List (APL) 42

12 APL Inclusion Request..... 46

Appendix A: RESIDENTIAL SOLAR WATER HEATING PROGRAM RULES 52

Appendix B: Hawai'i Energy Brand Guide 65



List of Tables

Table 1: Minimum water storage for retrofit SWH installations.....25

Table 2: Daily BTU requirements for common nominal size residential heaters & storage tanks26

Table 3: Tilt Factor27

Table 4: Recommended support structure anchors27

Table 5: Recommended conductor size for PV powered pumps (One way distance)27

Table 6: Solar Collector Output (BTU/day)27

Table 7: Recommended Thermosiphon System Tank Supports, Support Anchoring Fasteners & Tank27

List of Charts & Figures

Chart 1: Collector Orientation Factor Compass.....33

Figure 1: Bottom-Return Residential Forced Circulation System Design. Source: Hawaiian Electric Co.....34

Figure 2: Side-Return Residential Forced Circulation System Design. Source: Hawaiian Electric Co.....35

Figure 3: Top-Return Residential Forced Circulation System Design. Source: Hawaiian Electric Co.....36



Preface

The Hawai'i Energy Solar Water Heating Program Handbook consists of guidance, standards, recommended practices, and technical information for solar thermal systems for the purpose of eligibility for the Hawai'i Energy solar rebate.

The handbook provides a general description of the system components that are used for solar water heating systems. These descriptions are intended to provide the user with a basis for understanding why certain equipment might be required and how it should be configured.

It is the ultimate responsibility of the contractor to validate the performance of the equipment in the user setting and to ensure that appropriate operating and maintenance manuals are available and provided.

The verbal forms used in this Handbook are as follows:

- “must” or “shall” means that compliance with a requirement is mandatory
- “should” means that compliance with a requirement is recommended but is not mandatory for compliance
- “may” is used to describe a permissible way to achieve compliance with a requirement. In some cases, pre-authorization may be required prior to actual execution.

This Handbook reflects the conscientious efforts of industry professionals and manufacturers to develop guidelines and best practices for solar water heating systems in the counties of Honolulu, Hawai'i Island, and Maui.

This Handbook is directed towards the professionals intending to apply for Hawai'i Energy Solar Water Heating Program rebates and is not intended for regulatory application.



PART I: General



Standards & Specifications

Part I– General

12.1. PROGRAM APPLICATION AND RULES

The Application and Rules of the Hawai'i Energy Solar Water Heating Program, in their entirety, are hereby incorporated into these Program Standards & Specifications. There are specific Program mandates in these Standards and Specifications; the remaining recommendations are best practices.

12.2. OTHER DOCUMENTS

Program figures, forms, tables, charts, approvals, *Accepted Parts List (APL)*, and *Policies and Procedures* referred to herein are hereby incorporated into these Program Standards & Specifications.

12.3. SYSTEMS

Solar thermal systems installed under the Hawai'i Energy Solar Water Heating Program (“the Program”) shall conform to applicable local building, plumbing, and electrical codes, the manufacturer’s specifications and guidelines, these Standards and Specifications and shall be authorized by Hawai'i Energy prior to system installation. Where discrepancies, if any, exist between local codes and these Standards & Specifications, system installations shall conform to the higher standard as determined by Hawai'i Energy.



12.4. SYSTEM DESIGN

Systems shall be designed specifically for residential water heating. Systems shall be of forced circulation or thermosiphon design, which contain potable water.

- Systems may consist of single or multiple tanks and/or collectors.
- Multiple tank systems shall have the tanks connected in series. Multiple collector systems shall have the collectors connected in parallel.
- Single and multiple collectors shall be plumbed in a reverse return (i.e., opposite-end) method to achieve balanced flow through collectors.
- The solar return collector connection shall be at the highest point on each collector or adjacent multiple collectors.
- Systems shall be designed to prevent back-siphoning.
- Standard system designs for forced circulation systems are bottom-return, side-return and top-return. Side-return and top-return system designs shall incorporate check valve and heat loops.
- Multiple tank bottom-return system designs shall incorporate check valves.
- Forced circulation system component sequence will reference the following figures in the Hawai'i Energy SWH Design Guidelines (SWH Handbook):
 - *Figure 1* - for bottom- return systems.
 - *Figure 2* - for side-return systems; and
 - *Figure 3* - for top-return systems.
- Thermosiphon system designs shall conform to the manufacturer's recommendations. System mounting method shall conform to the manufacturer's recommendations. Systems installed in areas which experience freezing conditions shall incorporate appropriate freeze protection measures.



12.5. SYSTEM PERFORMANCE

Systems shall be designed to provide a minimum of 90% of the annual average water heating load, except as provided for in 1.6.4 Solar Fraction of these Standards and Specifications; to provide consistency of performance over the life of the system; and to achieve a minimum 20 year useful life as designated in the Hawai'i Energy Technical Reference Manual (TRM).

- Exterior located tanks, pumps, controllers, and timers shall be permanently protected from inclement weather. Unless otherwise specified on the invoice, the contractor will be held responsible for the protection.

12.6. SYSTEM SIZING – SOLAR FRACTION

Systems shall be sized to yield an acceptable solar fraction. Solar fraction, expressed as a percentage, is the contribution by the solar water heating system to the average daily water heating requirements. Solar fraction is a function of the actual system hot water storage, design finish tank temperature, daily BTU requirement to achieve design finish tank temperature, and daily collector output as determined by collector tilt, orientation, and sunshine zone.

12.6.1. Water Storage

The minimum water storage for the combined capacity of the primary and any additional tanks in retrofit systems shall meet requirements listed in [Table 1](#).

Note:

- 65 gallon or 80-gallon tanks may be installed for homes with 3 or less occupants.
 - In either case, the appropriate solar fraction must be met.



12.6.2. Finish Tank Temperature

A design finish tank temperature of 130°F shall be used for system sizing.

12.6.3. Daily BTU requirement

The daily BTU requirement shall be determined in [Form 1](#) by multiplying the total actual system storage in gallons (Line 10 on Form 1) by 8.33 lbs. per gallon times 1 BTU/lb., times the temperature rise, which is the difference between the design finish tank temperature (130°F) and the annual average inlet water temperature in SWH Handbook [Table 2](#).

Note that Maui County has variable inlet ground water temperatures.

Example calculation:

$$\begin{aligned}
& \text{Determined in Form 1, Line 10: } \text{Gallons} = \text{Determined in Form 1, Line 10} \\
& \text{Temperature Rise: } 130^{\circ}\text{F} - \text{Annual Average Inlet Water Temperature} = \text{Temperature Rise} \\
& \text{Daily BTU Requirement} = \text{Gallons} \times 8.33 \frac{\text{Lb.} \times 1 \text{ BTU}}{\text{Gal.} \times \text{Lb.}} \times (\text{Temperature Rise})
\end{aligned}$$



12.6.4. Solar Fraction

The solar fraction shall be determined by dividing the *Total Adjusted Collector BTU/Day Output* (Line 17, [Form 1](#) - Residential System Verification Form) by the *Total Actual System Storage Daily BTU Requirement* (Line 10 on [Form 1](#) - Residential System Verification Form).

- The system design solar fraction shall be not less than 90% and not more than 110% of the total actual system storage BTU requirement for systems in all sunshine zones.
- When the required storage equals the actual storage as determined on the [Form 1](#), the design solar fraction shall be not less than 95% and not more than 110% of the total actual system storage BTU requirement.
- The Program may allow a system Solar Fraction as low as 80% with written submission detailing concerns and reasons for low calculated solar fraction.
 - The intent of this rule is to reduce overheating of systems in micro-climate zones.
- Written request submission must include, but is not limited to, the following information:
 - Description of Request:
 - Homeowner contact information and utility account number
 - Reason for reduced solar fraction
 - Solar fraction calculation (with de-rating as applicable)
 - Participating Contractor information
 - Attached supporting documents and justification
 - All required documentation for submission (Application, [Form 1](#), etc.)



12.7. COLLECTOR TILT

Collectors shall be tilted no less than manufacturer's recommended minimum or more than 60 degrees from the horizontal. Collectors shall have their output rating de-rated by percentages listed in SWH Handbook [Table 3](#).

- If the manufacturer's minimum is unstated or not clearly defined, the minimum allowable tilt shall be 15 degrees to minimize potential overheating during the summer months and to achieve improved energy savings during the winter months.

12.8. COLLECTOR ORIENTATION

- Collectors shall be oriented between South of due East and South of due West.
- Collectors oriented east of 135 degrees true or west of 225 degrees true shall have their output de-rated by the percentages shown in the SWH Handbook on [Chart 1: Collector Orientation Factor Compass](#). [Chart 1](#) shows allowable collector orientations and orientation factors corrected for magnetic deviation.
- For side and end tilted collectors with compound angles, the orientation angle shall be calculated as if the collector(s) were flush mounted and then adding or subtracting 90 degrees.
- For systems being considered outside the recommended orientation, the Program may approve on a case-by-case basis, provided sufficient reasoning and sizing details are explained and optimal solar fraction is achieved.
 - Written waiver request shall be submitted prior to installation. Refer to Section 1.6.4. for detailed requirements.

12.9. COLLECTOR SHADING

Collectors shall not be shaded by any permanent obstacle at any portion of the time after 9:00 a.m. or before 3:00 p.m. on any day of the year, except by prior Hawai'i Energy approval before system installation.



12.10. DEMAND RESPONSE (DR) READY

Tank systems are recommended to be installed with consideration for demand response equipment installation. This would include access to install tank temperature measuring devices, a control box, and a nearby AC power outlet. If the customer and or contractor are pursuing demand response capable technologies, notify the Program for additional information and potential support.



PART II: Products



2 PRODUCTS

2.1 GENERAL

All solar collectors, solar tanks, and time switches shall be accepted for use in the Program by Hawai'i Energy prior to system installation. Specific product catalog data; equipment test data, manufacturer's written installation instructions; and detailed manufacturer's written product warranty statements shall be submitted only by Participating Contractors or local product suppliers to Hawai'i Energy for product acceptance consideration. Accepted products shall be listed on an [Accepted Products List](#). The acceptance, rejection, or de-listing of any product from the [Accepted Products List](#) shall be within the sole discretion of Hawai'i Energy.

2.2 COLLECTOR RATINGS – GENERAL

- Collectors shall have a current Solar Rating & Certification Corporation (SRCC) OG-100 rating and certification. The OG-100 standard expresses irradiance in Btu per square foot per day as a function of sky condition and application.
 - A clear sky is defined as 2,000 Btu/(sq. ft. day).
 - A mildly cloudy sky is defined as 1,500 Btu/(sq. ft. day).
 - A cloudy sky is defined as 1,000 Btu/(sq. ft. day).
- The application for the Hawai'i Energy program shall be *Category C - Water Heating (Warm Climate)*. OG-100 Category C collector output data shall be converted to calories per square centimeter per day for each of the various Hawaii Sunshine Zones.
- [Table_6](#) of the SWH Handbook lists accepted collectors and their output ratings for each sunshine zone (source: hawaii.gov/dbedt).
 - The sunshine zone closest to the collector installation site shall be used to determine collector output.
 - Sites equidistant between two zones may be in either zone.
 - Sites in the 300 zone shall be in a 350 zone for system sizing purposes.



2.2.1 Collector Ratings – Oahu

OG-100 Category C data for clear day, mildly cloudy and cloudy day sky conditions shall be interpolated to align with the Oahu Sunshine Map at 500, 450, 400, 350 and 300 calories per square-centimeter per day.

2.2.2 Collector Ratings – Maui, Molokai, and Lanai

OG-100 Category C data for clear day, mildly cloudy and cloudy day sky conditions shall be interpolated to align with the Maui and Molokai Sunshine Map at 500, 480, 400, 350 and 300 calories per square-centimeter per day. The island of Lanai shall be deemed a 400-sun zone with the exception of Manele. Manele on Lanai shall be deemed a 500 zone. See [Table 2](#) for additional sizing adjustments specific to Maui County.

2.2.3 Collector Ratings – Big Island of Hawaii

OG-100 Category C data for clear day, mildly cloudy and cloudy day sky conditions shall be interpolated to align with the Hawaii Sunshine Map at 550, 500, 450, 400, 350 and 300 calories per square-centimeter per day.

2.3 COLLECTOR MATERIALS

For flat plate collectors, collector frame material shall be aluminum, stainless steel, copper or an approved equal. Collector glazing shall be low iron tempered solar glass. Collector waterways shall be of Type M minimum copper tube. Other collector materials are acceptable, subject to prior approval by Hawai'i Energy.

2.4 COLLECTOR/SYSTEM MOUNTING BRACKETS

Collector/system mounting brackets which secure the collector/system to the support structure or directly to the roof structural member shall be designed specifically for the equipment to be bracketed and shall be fabricated by an established manufacturer.

2.5 COLLECTOR/SYSTEM LEG SETS

Collector/system leg sets which secure the collector/system to the support structure or directly to the roof structural member shall be designed specifically for the equipment to be supported and shall be fabricated by an established collector/system leg set manufacturer.



2.6 COLLECTOR/SYSTEM SUPPORT STRUCTURE

Collector/system support structure shall be of structurally sound material. The material shall be of non-corrosive metal channel or similar sections of approved material and finish which are compatible with the collector, collector mounting brackets, collector leg supports, and leg set cross braces. Acceptable support structure materials are extruded aluminum solar strut, channel and double T, isolated galvanized steel, and UV resistant plastic.

Unless otherwise approved by Hawai'i Energy prior to system installation:

- solar strut shall be 1-5/8" x 1-5/8" x 1/8" in size,
- channel and double T shall be 3" x 1" x 1/8" in size, and
- angle aluminum shall be 2" x 2" x 3/16" in size.
- Wood or wood products are not acceptable.

2.7 TANKS

Tanks shall be designed specifically as residential water heaters or water storage tanks.

- New tanks shall be warranted by the manufacturer for at least 6 years and shall be listed in the Hawai'i Energy [Accepted Products List \(APL\)](#).
- Non-solar tanks shall be rated as high-efficiency electric water heaters.
- Where use of high-efficiency electric water heaters is not practical, the new tank shall be listed in the AHRI Directory of Certified Product Performance (formerly known as Gas Appliance Manufacturers Association Consumers' Directory of Certified Efficiency Ratings).

Incorporation of existing water heaters and/or storage tanks into the solar water heating system shall be accepted at the sole discretion of the Hawai'i Energy.

In single tank systems, the tank shall be equipped with an internal thermostat and heating element rated at not more than 4,500 Watts. In single tank systems, the lower element, if any, shall be disabled at the upper element.

In multiple tank systems, the tank which directly supplies the hot water load shall have an internal thermostat and heating element of an approved rating and the lower element, if any, shall not be disabled.

If the tank is situated in a location that is exposed to the elements, an enclosure or 24" overhang is required to protect the tank from the elements to meet a 20-year system life by design.

2.8 PUMPS



Pumps shall be of a circulating type. The pump shall be designed to attain the manufacturer's recommended collector flow rate for the total number of system collectors and the total developed head of the solar lines.

- AC powered pumps shall be compatible with the pump controller.
- DC powered pumps shall be compatible with the photovoltaic module.
- Pump iso flanges are not acceptable in lieu of ball valves.

2.9 CONTROLLER

Controller shall automatically control the operation of the circulating pump so that optimum system performance is attained. The controller shall be compatible with the circulating pump.

2.10 PHOTOVOLTAIC MODULES

Photovoltaic modules used to power DC pumps shall be compatible with the pump's performance rating and power requirements.

2.11 TIME SWITCHES

All systems shall have time switches, which control the operation of the auxiliary heating system. Acceptable time switches are electric, electronic, and spring-loaded mechanical switches. Electric and electronic time switches shall have a manual override feature. Digital time switches offer additional features such as weekday and weekend scheduling as well as vacation mode settings. Also, time switches with a back-up power source may ensure timer accuracy over the life of the system. Contact the Program for more information on time switches with back-up power, or to recommend additional timers to be included in the APL.

2.12 PIPING

- Piping shall be copper tubing Type M minimum or stainless-steel Grade 304 / 316 approved for potable water piping.
- Solar supply and return pipe shall be sized to attain the manufacturer's recommended collector flow rate for the total number of system collectors and pump size.
- The pipe size for forced circulation systems with less than 120 sq. ft. of collector area and less than 120 feet total round trip distance shall be 1/2-inch minimum.
- The pipe size for forced circulation systems with collector area greater than 120 sq. ft. and/or greater than 120 feet total round trip distance shall be approved by Hawai'i Energy prior to system installation.
- The pipe size for water heater/storage tank supply, distribution, multiple tank interconnections and overflow lines shall be 3/4-inch minimum.



For non-pressurized lines such as tank discharge line, any code approved piping will be allowed. The hot and cold supply lines to a thermosiphon system shall have a pipe size of 3/4" minimum. Water heater flex connectors may be used and can be soldered or metal to metal connector type (ground joint seal). Flex connectors utilizing washer seals are not acceptable. Chlorinated Poly Vinyl Chloride (CPVC) and cross-linked high-density polyethylene (PEX) shall not be used on the solar supply or return lines.

2.13 FITTINGS

Fittings, hose bibs, and drains shall be bronze, brass, or wrought copper approved for potable water distribution. Contact with any dissimilar metals such as, copper or copper-alloy to galvanized steel can result in corrosion and subsequent leaking at the joint. See section 2.15 UNIONS for additional guidance.

2.14 VALVES

Valves shall be bronze or brass.

2.14.1 Ball Valves

- Ball valves shall be provided to isolate major system components such as tanks, collectors and circulating pumps.
- Factory supplied pump isolation flanges are acceptable to isolate the pump in lieu of ball valves.
- A ball valve or pump isolation flange is not required between the tank and pump if the bottom portion of the pump remains above the top of the tank.

2.14.2 Check Valves

- Check valves shall be provided with side-return, top-return and multiple-tank, bottom-return forced circulation systems or where back-siphoning may occur.
- Check valves shall be of the spring or swing check type at installing contractor discretion.
- Check valves shall be installed so gravity will not keep flapper/seat open.



2.14.3 Flush Out Valves

- Flush out valves shall be provided to allow for storage tank and collector draining and periodic flushing.
- All contractor installed flush out valves shall have thread caps with hose washer securely attached to the valve.
- Acceptable valves are hose bibs and boiler drains.

2.14.4 Pressure Relief Valve

- A pressure relief valve shall be provided at the collector(s).
- The pressure setting shall be non-adjustable and shall be rated at 125 or 150 PSI.
- The valve lever shall be stainless steel and the valve pin shall be brass.

2.14.5 Temperature & Pressure Relief Valve

- A temperature & pressure relief valve shall be provided for single or multiple pressurized water storage tank systems provided the location complies with local code requirements.
- The temperature and pressure relief settings shall be non-adjustable and shall be rated at 210°F and 150 PSI, respectively.

2.15 UNIONS

- Unions shall be bronze or brass.
- Directly joining two different types of metals, such as steel and copper, can cause rapid corrosion at the joint. Therefore, joints between copper or copper alloy tubing and galvanized steel pipe shall be made with a brass converter fitting or dielectric fitting.

2.16 TEMPERATURE MEASURING DEVICE

A temperature-measuring device shall be provided to measure the temperature of the storage tank, which directly supplies the hot water load. Acceptable temperature measuring devices are temperature gauges and electronic temperature devices. For roof, mounted tanks, a temperature measuring device shall not be required on inaccessible or roof top hot water supply lines.



2.17 INSULATION

Piping insulation shall be flexible and elastomeric with a minimum wall thickness of 1/2" and a minimum design temperature of 220°F. See details in section 3.8 PIPING INSULATION.

2.18 SOLDER

Solder shall be lead free. Crimp connections shall not be used on the solar feed and return lines.

2.19 FLASHING

Flashing, when used, shall be designed to positively seal roof penetrations resulting from the solar water heating system installation. Acceptable flashing materials are lead, copper, aluminum, or other approved material. Lead shall not be used where water supplying a catchment system contacts the flashing.

2.20 OTHER PRODUCTS

Neoprene, EPDM spacers, or other approved material shall separate corrosion causing dissimilar metals. Minor component products not otherwise listed in these standards and specifications may be used if their use does not detract from overall system performance.

2.21 PRODUCT WARRANTIES

- Manufacturer warranties shall apply to all products.
- Collectors shall be warranted for a minimum of 10 years.
- Tanks shall be warranted for a minimum of 6 years.



PART III: Execution Guidelines



3 Part III – Execution Guidelines

3.1 GENERAL

Solar water heating system installations shall result in fully operational systems that comply with the warranties of the manufacturer and/or vendors (see section 2.21). Solar water heating systems shall be installed by licensed solar water heating contractors approved by Hawai'i Energy. All required governmental permits shall be issued prior to system installation. Installations shall be in accordance with these Standards and Specifications and applicable governmental codes or manufacturer's recommendations where they meet or exceed these Standards and Specifications. Systems shall be installed in a professional, workmanlike manner using products from Hawai'i Energy's [Accepted Products List \(APL\)](#)

3.2 COLLECTORS/SYSTEM

Solar collectors/systems, mounting brackets, leg sets, support structure and support structure anchoring fasteners shall be attached to form a secure mechanical bond between adjoining components and the roof structural members.

3.2.1 Collectors/Systems

In multiple collector systems, collectors shall be installed with the same tilt and orientation or as approved by Hawai'i Energy prior to system installation.

3.2.2 Mounting Brackets

Mounting brackets shall secure flush mounted collectors directly to the collector support structure or the roof structural members. Unless otherwise provided by the collector manufacturer, a minimum of four brackets per collector shall secure each flush mounted collector. For mounting brackets, which require penetration of the collector box, the number of fasteners attaching each bracket to the collector shall equal the number of holes in the bracket, unless otherwise provided by the collector manufacturer. Collector box penetrations are allowed unless such penetrations are prohibited by collector manufacturer. Brackets attached directly to roof structural members shall be secured with a minimum required length and diameter anchoring fastener. Brackets attached to support structures shall be secured with locknut sets on "solar strut" and with through-bolt sets on channel, and with lag-bolt sets on approved plastic lumber.



3.2.3 Leg Sets

Leg sets shall secure tilted collectors directly to the collector support structure or the roof structural members. The type, number, location, and installation method of leg sets shall be in accordance with the collector manufacturer's recommendations. Unless otherwise provided by the collector manufacturer, each tilted collector shall be supported by a minimum of two leg sets. For leg set brackets which require penetration of the collector box, the number of fasteners attaching the collector leg sets to the collector shall equal the number of holes in the leg set bracket, unless otherwise provided by the collector manufacturer. Collector box penetrations are allowed unless such penetrations are prohibited by collector manufacturer. Leg sets shall be secured to the support structure with strut-nut sets on "solar strut" and with through-bolt sets on channel, and with lag-bolt sets on approved plastic lumber. Leg sets which are four feet (4') or longer in length shall be cross braced diagonally. Cross braces shall be through bolted to the leg sets.

3.3 TANKS

Water heaters and/or storage tanks shall be plumbed so that the attached equipment, cover plates and warning labels are visible and accessible. Attached equipment shall be defined as pump, controller, time switch, piping and any other components attached or connected to the tank. All pressurized tanks shall be equipped with a securely attached temperature and pressure relief valve. Piping connections to the tank shall be made with brass or bronze fittings. Adjustable auxiliary heating thermostats shall be set between 110 °F and 120°F.

3.3.1 Ground Mounted Tanks

Vertical and horizontal ground mounted tanks shall be set level on concrete or other approved base extending not less than three inches (3") above the adjoining ground level. Cement bricks placed between the tank and the supporting base shall support tank(s). Cement bricks shall be whole and of a nominal minimum size of 2" high, 3" wide and 7" long. A minimum of three bricks evenly spaced shall be used to support vertical tanks. Bricks are not required for tanks with non-metallic bottoms. Horizontal tanks shall be supported in accordance with the tank manufacturer's recommendations or as approved by Hawai'i Energy prior to system installation. Acceptable leveling devices are manufactured plastic shims.

- In side-return, top- return single and multiple tank systems, the solar return line shall be plumbed with a heat loop which extends to within 12" of the bottom of the tank.
- Required check valves shall be installed horizontally on the solar return line at the bottom of the heat loop.



- In bottom-return multiple tank systems, the required check valve shall be installed horizontally at the solar return line connection to the tank drain port.
- Nipples replacing manufacturer supplied tank drain valve shall be of sufficient length to allow adequate access to tank sensor.
- All contractor installed flush out valves shall have threaded caps with hose washer securely attached to the valve.
- The tank drain valve assembly shall be installed at the lowest part of the tank.

3.3.2 Roof Mounted Tanks

Roof mounted thermosiphon system tanks shall be supported by the number of tank supports, support fasteners and tank mounting brackets recommended by the manufacturer or those which correspond to the tank length ranges shown in SWH Handbook on

Table , whichever is greater.

3.3.3 Tank Supports and Fasteners

The number of supports and fasteners are in

Table 4 is based on roof structural member spacing of 24" on center or less. The number of tank supports and support fasteners for roof structural members with spacing greater than 24" shall be approved by Hawai'i Energy prior to system installation. The length of tank supports shall be not less than the tank diameter or width and shall conform to *Section 2.6 Collector/System Support Structure* of these Standards & Specifications. Each tank support shall be installed parallel to and directly over a roof structural member. Acceptable leveling devices are sheet aluminum. Each tank support shall be securely attached to the roof structural member with a minimum of 2 anchoring fasteners per support, which shall be located no farther than 4" from the ends of each support.

3.3.4 Tank Mounting Brackets

Tank mounting brackets shall be located on and secured to opposite sides of each tank support. Tank mounting brackets shall be secured to the tank supports with strut nut sets on "solar strut", with through-bolt sets on channel, and with lag bolt-sets on approved plastic lumber.



3.4 CONTROLLERS

Pump controllers shall be installed in accordance with manufacturer's recommendations. The controller should be installed so it is easily accessible and operable. The top of the controller shall not be higher than 6 ft. 7 in. above the floor/ground level and shall not be located behind the tank. Sensor placement recommendations are as follows:

- Controller sensors shall be attached at the hottest and coldest points in the solar piping loop by stainless steel clamps.
- The sensor shall be installed as recommended by controller/sensor manufacturer
- Collector sensors shall be attached no farther than 6" from the collector header connection to the solar return line
- Tank sensors shall be attached no farther than 12" from the coldest point at the tank as measured along the solar supply line
- Attachment of the tank sensor to factory provided tank sensor stud is permitted. When attached to stud, sensor shall be attached with a nut.
- Controller sensor attachment shall form a positive mechanical bond between the sensor and the sensing point to optimize heat transfer to the sensor.
- The sensor shall be clamped on its flanged end, or as recommended by controller/sensor manufacturer.
- Clamping of sensors over the sensor "barrel" end is unacceptable
- Sensors shall be connected to sensor wire with all plastic wire nuts. Wire nuts shall be sealed with silicon and wrapped with electrician's tape; and
- Sensor wiring shall be secured in a workmanlike manner.

3.5 TIME SWITCHES

Time switches shall be installed in accordance with manufacturer's recommendations. The time switch should be installed so it is easily accessible and operable.

- The top of the time switch shall not be higher than 6 ft. 7 in. above the floor/ground level and shall not be located behind the tank.
- Optimal Time switch settings are as follows:
 - At a minimum, electric time switches shall have at least one "off" tab securely affixed to the face of the timing mechanism (9:00 AM or earlier is ideal)
 - Timer energizes thermostat 5am-7am, then OFF
 - Timer shall be set so that tank thermostats are not energized during the solar day (i.e., between 9:00 AM and 3:00 PM)
 - Timer may also be set for 4 PM "energized", 5 PM "OFF"
- Electronic time switches shall be programmed to turn off within 24 hours of being turned on
- Multiple automatic time switch settings, exclusive of the solar day, may be used



- Time switch wiring shall be secured in a workmanlike manner; and
- Time switches with battery or mechanical back-up power should be used

3.6 PHOTOVOLTAIC MODULES

Photovoltaic modules shall be securely installed with approved support structure materials in the same tilt and orientation as the system collectors. Module location shall conform to Section 0 COLLECTOR SHADING. Wire nuts used to interconnect module and pump shall be all plastic and shall be sealed with silicon and wrapped with electrician's tape. Photovoltaic wiring shall be secured in a workmanlike manner.

3.7 PIPING, FITTINGS AND VALVES

Solder joints shall be sanded, fluxed, and soldered with approved solder. Threaded fittings and valves shall be wrapped with Teflon or equal tape and/or joint sealant. Piping shall be plumb and level where practical. Vertical piping shall be supported at each story or at maximum intervals of 10 feet. Horizontal piping shall be supported at approximately 6-foot intervals. Pipe supports shall not penetrate piping insulation. Rooftop piping shall be raised off the roof by blocks or spacers. Blocks/spacers shall be placed at approximately 6-foot intervals on straight runs and not more than 2 feet of each side of an angular joint. Piping shall be attached to blocks/spacers with acceptable pipe supports. Blocks/spacers shall be adhered to the roof. Roof penetration shall not be made to attach blocks/spacers to the roof. Valves, including hose bibs and boiler drains, shall be installed in the sequence shown on the *Plumbing Layout Figures*. Collector flush-out valves (not located on the roof) and the tank drain valve on bottom-return systems shall have their ports securely capped with a brass/bronze cap.

3.8 PIPING INSULATION

Insulation shall be installed on all new hot water piping, including solar supply and return lines and on accessible existing hot and cold-water supply pipe for a minimum of 6 feet leading to the system (measured from the tank). For accessible pipe, less than 6 feet in length, the entire accessible length shall be insulated. Insulation is not required on the cold-water supply line to thermosiphon systems.



At the installing contractor's discretion, the tank temperature & pressure relief overflow line and collector pressure relief overflow line, where present, may be insulated. Insulation butt joints shall be sealed in accordance with manufacturer's recommendations. Packing of insulation butt joints in attics and within walls, in lieu of sealing, is acceptable. Abutment of valves, unions and tees with pipe insulation is acceptable. Insulation shall in no way restrict the operation of any valve. Collector headers and interconnections shall be insulated. Collector headers and interconnections insulation may be slit and NY-tied with UV resistant cable ties without sealing. The entire circumference of exterior exposed insulation shall be UV protected. Acceptable UV protection is latex based paint or another approved product. UV protection of insulation on exterior vertical piping is acceptable.

3.9 ROOF / WALL / CEILING PENETRATIONS (related to installation)

Roof penetrations resulting from the installation shall be detailed on system mounting detail drawings and shall be positively sealed in accordance with standard roofing practices. Flashing installed on metal roofs shall be compatible with the roofing material. Exterior/interior wall penetrations created about the installation shall be made watertight. Interior wall and ceiling penetrations created during work shall be sealed.

3.10 TEMPERATURE MEASURING DEVICE

In forced circulation systems, the temperature measuring device shall be installed at the hot water outlet port on the tank, which directly supplies the domestic hot water load. In thermosiphon systems, the temperature-measuring device shall be installed only on an accessible hot water supply after the storage tank and before any hot water fixture; the device shall not be required on inaccessible hot water supply lines.

3.11 OTHER PRODUCTS

Minor component products not otherwise listed in these standards and specifications shall be installed in a professional, workmanlike manner in accordance with the manufacturer's recommendations.

3.12 SYSTEM WARRANTY

Contractors shall provide full labor warranty for one year from the date of acceptance by Hawai'i Energy for each system installed.



Residential Solar Water Heating Tables



4 Residential Solar Water Heating Tables

Table 1: Minimum water storage for retrofit SWH installations

# Occupants	Est. Hot Water Use (Gallons/day)	Minimum Tank Storage (Gallons/day)	Est. Hot water use for sizing on Form 1 (20 gals/person)
3	45	65	60
4	55	80	80
5	65	80	100
6	75	80	120
7	85	120	140
Over 7	Add 10 gal per person		Add 20 gal per person



Table 2: Daily BTU requirements for common nominal size residential heaters & storage tanks

(Inlet water degree rise to tank temperature of 130°F)

Location	Avg. Inlet Water Temperature	Daily BTU Requirement			Data Source
		65 gallons	80 gallons	120 gallons	
Honolulu C&C Hawaii County	75°F	29,780	36,652	54,978	
Maui County					
Kahului Wailuku Paia Kihei Maalaea Wailea Makena	74°F	30,321	37,318	55,978	<i>Maui County BOWS</i>
Kaunakakai	74°F	30,321	37,318	55,978	<i>Contractor Consensus</i>
Lanai	74°F	30,321	37,318	55,978	<i>BOWS Estimate</i>
Kaanapali Lahaina Pukalani	71°F	31,946	39,318	58,976	<i>Maui County BOWS</i>
Makawao Haiku	69°F	33,028	40,650	60,976	<i>Maui County BOWS</i>
Hana	69°F	33,028	40,650	60,976	<i>BOWS Estimate</i>
Kalae, Molokai	69°F	33,028	40,650	60,976	<i>Contractor Consensus</i>
Lower Kula	68°F	33,570	41,317	61,975	<i>Maui County BOWS</i>
Upper Kula Olinda	64°F	35,736	43,982	65,974	<i>Maui County BOWS</i>



Table 3: Tilt Factors

Tilt (In degrees)	Collector De-rating % (Additional Collector BTU)
5° - 13°	5%
14° - 35°	0%
36° - 40°	5%
41° - 45°	10%
46° - 50°	15%
51° - 55°	20%
56° - 60°	25%
Greater than 60°	Not acceptable

Table 4: Recommended support structure anchors

(Applies to extruded aluminum sizes: 1-5/8" x 1-5/8" x 1/8" solar strut, 3" x 1" x 1/8" channel & double T, 2" x 2" x 3/16" angle)

Number of Collectors	Collector Size	Number of Anchors
1	any size	4
2	3' x 7' or 3' x 8'	4
	1 @ 3' x 8' and 1 @ 4' x 8'	4
	4' x 6' or 4' x 8' or 4' x 10'	6
3	3' x 7' or 3' x 8'	6
	2 @ 3' x 8' and 1 @ 4' x 8'	6
	1 @ 3' x 8' and 2 @ 4' x 8'	6
	4' x 6' or 4' x 8' or 4' x 10'	8
4	3' x 7' or 3' x 8'	8
	2 @ 3' x 8' and 2 @ 4' x 8'	8
	4' x 6x or 4' x 8' or 4' x 10'	10



Table 5: Recommended conductor size for PV powered pumps (One way distance)

Module Output	18 AWG	16 AWG	14 AWG	13 AWG	10 AWG	8 AWG
5 W	54 ft.	109 ft.	219 ft.	327 ft.	545 ft.	>1,000 ft.
10 W	26 ft.	52 ft.	104 ft.	456 ft.	269 ft.	429 ft.
20 W	n/a	56 ft.	52 ft.	78 ft.	130 ft.	208 ft.
43 W	n/a	n/a	24 ft.	36 ft.	60 ft.	96 ft.

Updated: January 2024 (supersedes all previous versions)
Table 6: Solar Collector Output (BTU/day)

Collector Description				Sunshine Zone					
Nominal Size	Coating	Manufacturer/Brand	Model	Hawai'i Only 550	500	Maui Only 480	450	400	350
3' x 7'	Paint	Solahart	J Collector	21,919	19,926	19,129	17,032	14,071	11,055
3' x 7'	Paint	Solahart	L Collector	16,743	15,221	14,612	12,715	10,135	7,697
3' x 7'	Paint	SunEarth	EP-21	21,716	19,742	18,952	17,222	14,662	12,037
3' x 7'	Selective	Alternate Energy	AE-21	21,219	18,599	17,551	15,979	13,359	10,739
3' x 7'	Selective	Alternate Energy	MSC-21	23,119	20,499	19,451	17,879	15,259	12,639
3' x 7'	Selective	R&R	SunPro21	16,236	14,760	14,170	12,430	10,037	7,697
3' x 7'	Selective	Solahart	Bt Collector	25,958	22,753	21,471	19,547	16,342	13,137
3' x 7'	Selective	Solahart	Kf Collector	23,542	21,402	20,546	18,645	15,842	12,967
3' x 7'	Selective	Solahart	LCS Collector	21,005	19,096	18,332	16,558	13,973	11,365
3' x 8'	Paint	SunEarth	EP-24	25,470	23,155	22,229	20,163	17,122	14,052
3' x 8'	Selective	Alternate Energy	MSC-24	26,372	23,420	22,239	20,468	17,516	14,564
3' x 8'	Selective	R&R	SunPro24	18,570	16,882	16,206	14,185	11,414	8,782
4' x 5'	Selective	SunEarth ThermoRay	TR-20	18,518	16,153	15,207	13,787	11,439	9,192
4' x 6'	Selective	Alternate Energy	AE-26	26,219	22,972	21,673	19,725	16,478	13,230
4' x 6'	Selective	Alternate Energy	MSC-26	28,513	25,303	24,019	22,093	18,882	15,672
4' x 6.5'	Selective	SunEarth ThermoRay	TRB-26	30,584	27,195	25,839	23,805	20,421	17,069
4' x 6.7'	Selective	SunEarth ThermoRay	TR-26	18,518	16,153	15,207	13,787	11,439	9,192
4' x 7'	Paint	Heliodyne	406-002	27,601	25,092	24,088	21,681	18,204	14,620
4' x 7'	Selective	Alternate Energy	MSC-28	31,572	27,993	26,561	24,414	20,834	17,255
4' x 7'	Selective	Heliodyne	406-001	30,138	27,398	26,302	23,816	20,172	16,480
4' x 8'	Paint	Heliodyne	408-002	33,182	30,166	28,959	26,046	21,845	17,564
4' x 8'	Paint	SunEarth	EP-32	34,704	31,550	30,288	27,517	23,419	19,269
4' x 8'	Selective	Alternate Energy	AE-32	33,149	29,090	27,466	25,031	20,972	16,913
4' x 8'	Selective	Alternate Energy	MSC-32	36,155	32,059	30,421	27,963	23,867	19,771
4' x 8'	Selective	Heliodyne	408-001	36,328	33,026	31,704	28,750	24,403	19,941
4' x 8'	Selective	R&R	SunPro32	24,963	22,694	21,786	19,072	15,350	11,830



Table 6: Solar Collector Output (cont'd)

Collector Description				Sunshine Zone					
Nominal Size	Coating	Manufacturer/Brand	Model	Hawai'i Only 550	500	Maui Only 480	450	400	350
4' x 8'	Selective	SunEarth ThermoRay	TRB-32	37,850	34,409	33,033	29,984	25,486	20,922
4' x 8'	Selective	SunEarth ThermoRay	TR-32	30,619	26,850	25,342	23,081	19,333	15,715
4' x 10'	Paint	Heliodyne	410-002	41,605	37,823	36,310	32,688	27,454	22,059
4' x 10'	Paint	SunEarth	EP-40	43,228	39,299	37,727	34,301	29,225	24,022
4' x 10'	Selective	Alternate Energy	AE-40	40,184	36,531	35,070	31,644	26,666	21,646
4' x 10'	Selective	Alternate Energy	MSC-40	45,214	40,122	38,085	35,030	29,938	24,845
4' x 10'	Selective	Heliodyne	410-001	45,359	41,236	39,586	35,867	30,406	24,848
4' x 10'	Selective	R&R	SunPro40	31,051	28,229	27,099	22,937	18,811	14,684
4' x 10'	Selective	SunEarth ThermoRay	TRB-40	47,389	43,081	41,358	37,527	31,882	26,192
4' x 10'	Selective	SunEarth ThermoRay	TRB-40	37,158	32,416	30,519	27,674	22,970	18,486



Table 7: Recommended Thermosiphon System Tank Supports, Support Anchoring Fasteners & Tank Mounting Brackets

Tank Length	Number of Tank Supports ¹	Number of Support Fasteners ²	Number of Tank Mount Brackets ³
48" – 56"	2	4	4
69" – 75"	3	6	6
91" – 108"	4	8	8
120" – 130"	5	10	10
160"	6	12	12

1. Based on typical rafter/joist spacing of 24" on center or less. For rafter/joist spacing greater than 24" on center refer to Section [3.3.3 Tank Supports and Fasteners](#).
2. Minimum of 2 support fasteners per support of 5/16" diameter for direct mount method. Fasteners are sufficient length to penetrate a minimum 1 3/4" into the roof structural member.
3. Tank mounting brackets shall be located on and secured to opposite sides of each tank support.



5 Collector Orientation Factor Compass

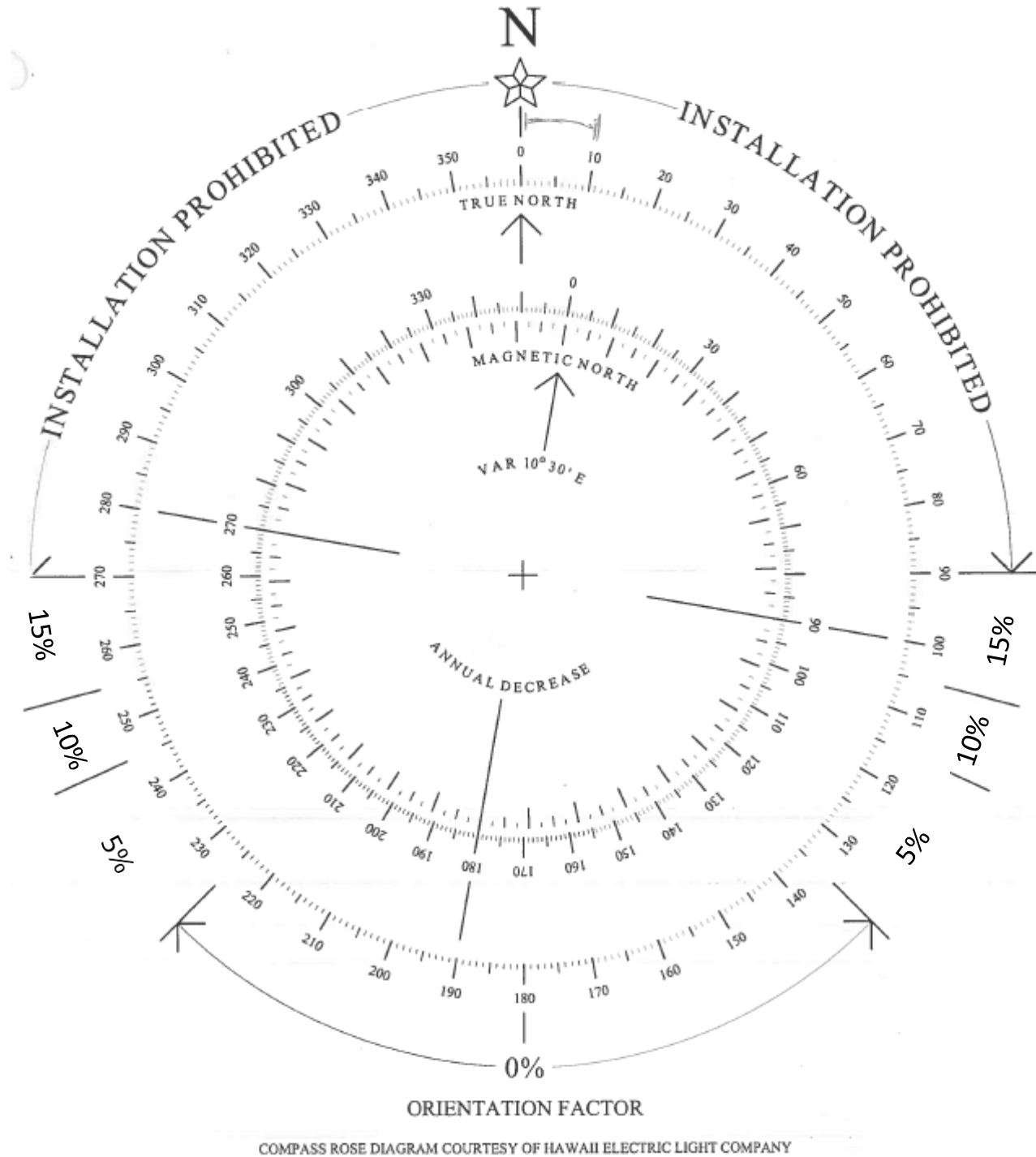

Chart 1: Collector Orientation Factor Compass



Plumbing Layout Figures

FIGURE 1.
BOTTOM-RETURN RESIDENTIAL FORCED CIRCULATION SYSTEM DESIGN

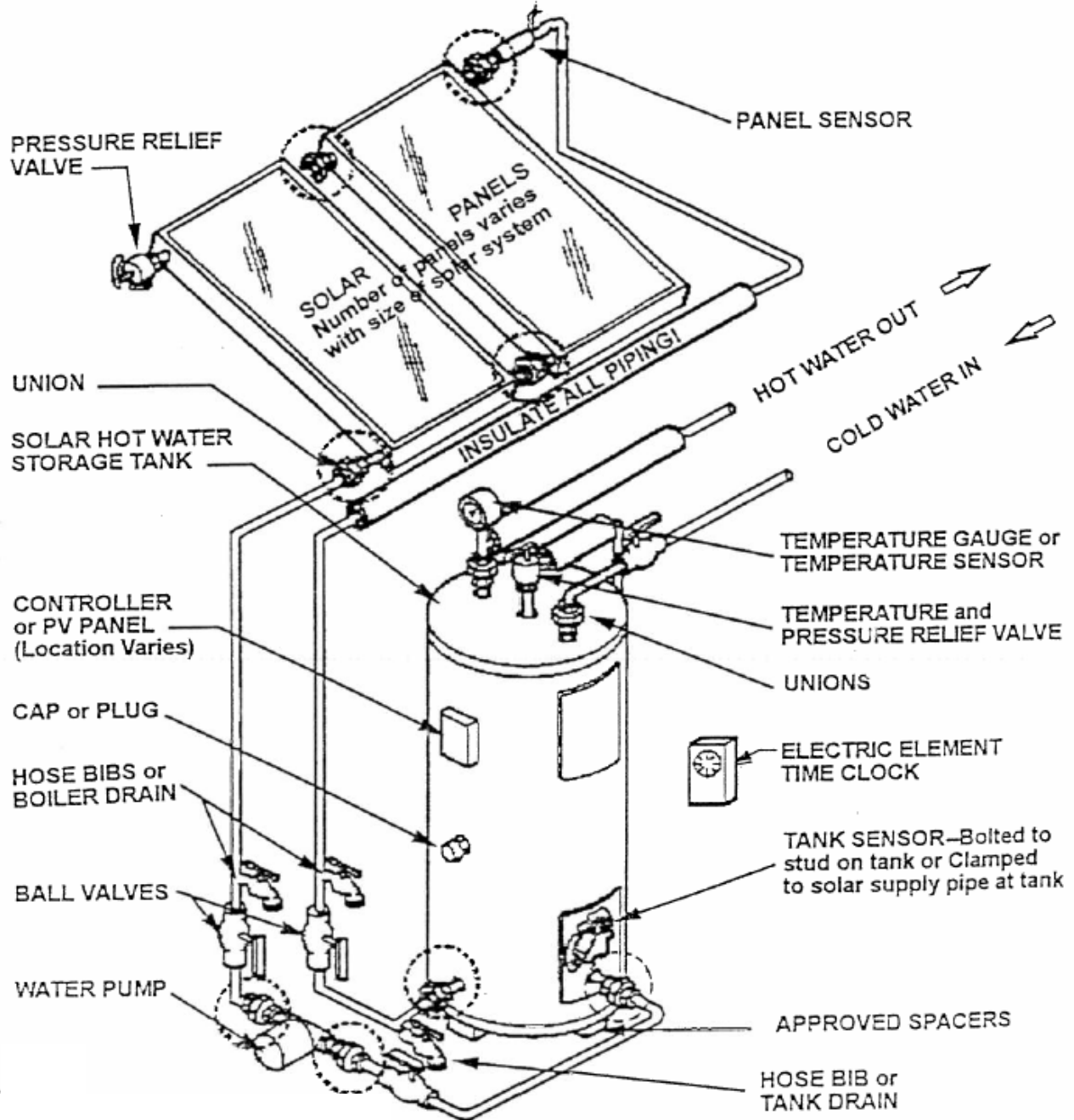

Figure 1: Bottom-Return Residential Forced Circulation System Design. Source: Hawaiian Electric Company



FIGURE 2.
SIDE-RETURN RESIDENTIAL FORCED CIRCULATION SYSTEM DESIGN

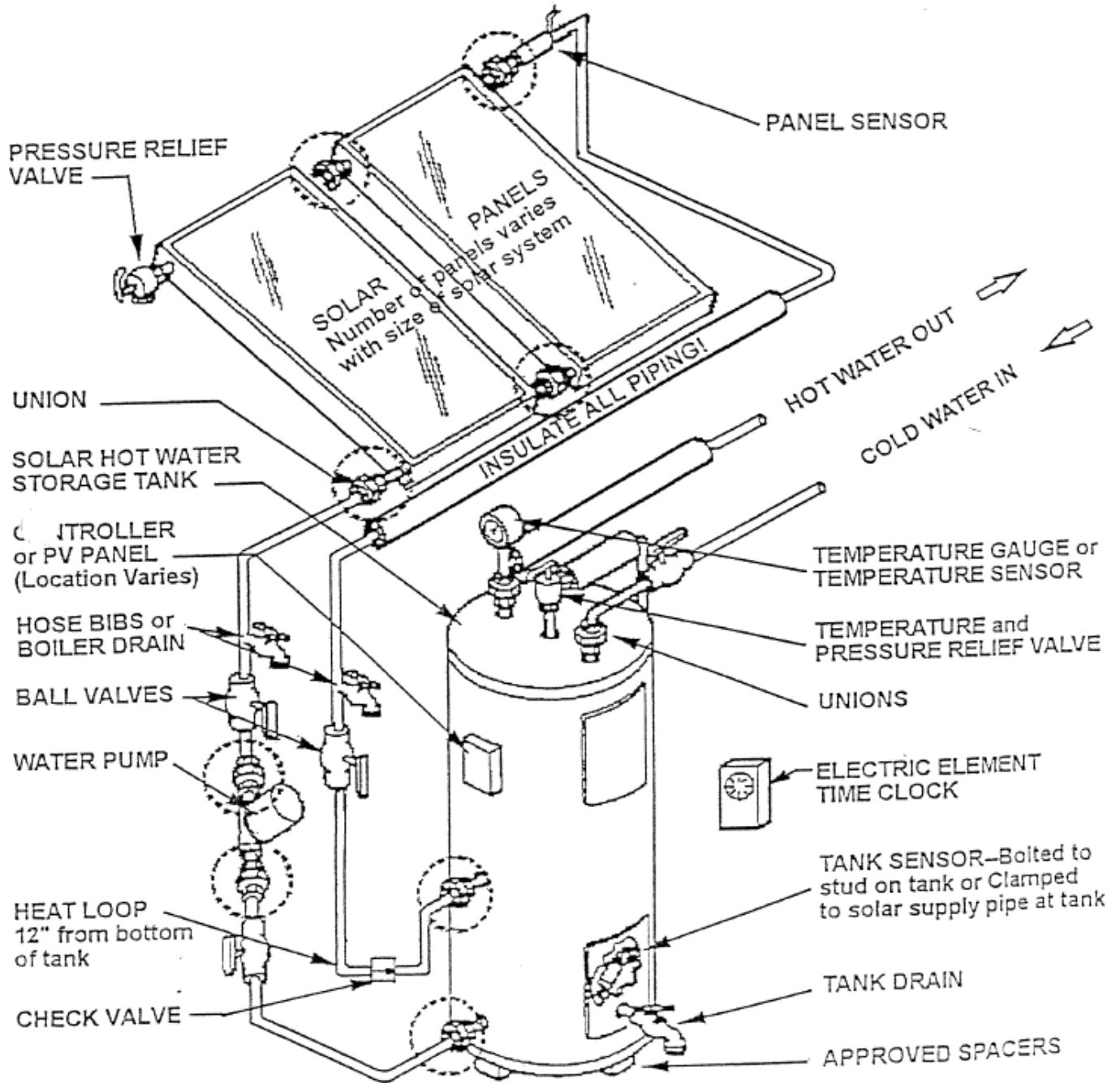

Figure 2: Side-Return Residential Forced Circulation System Design. Source: Hawaiian Electric Company



FIGURE 3.
TOP-RETURN RESIDENTIAL FORCED CIRCULATION SYSTEM DESIGN

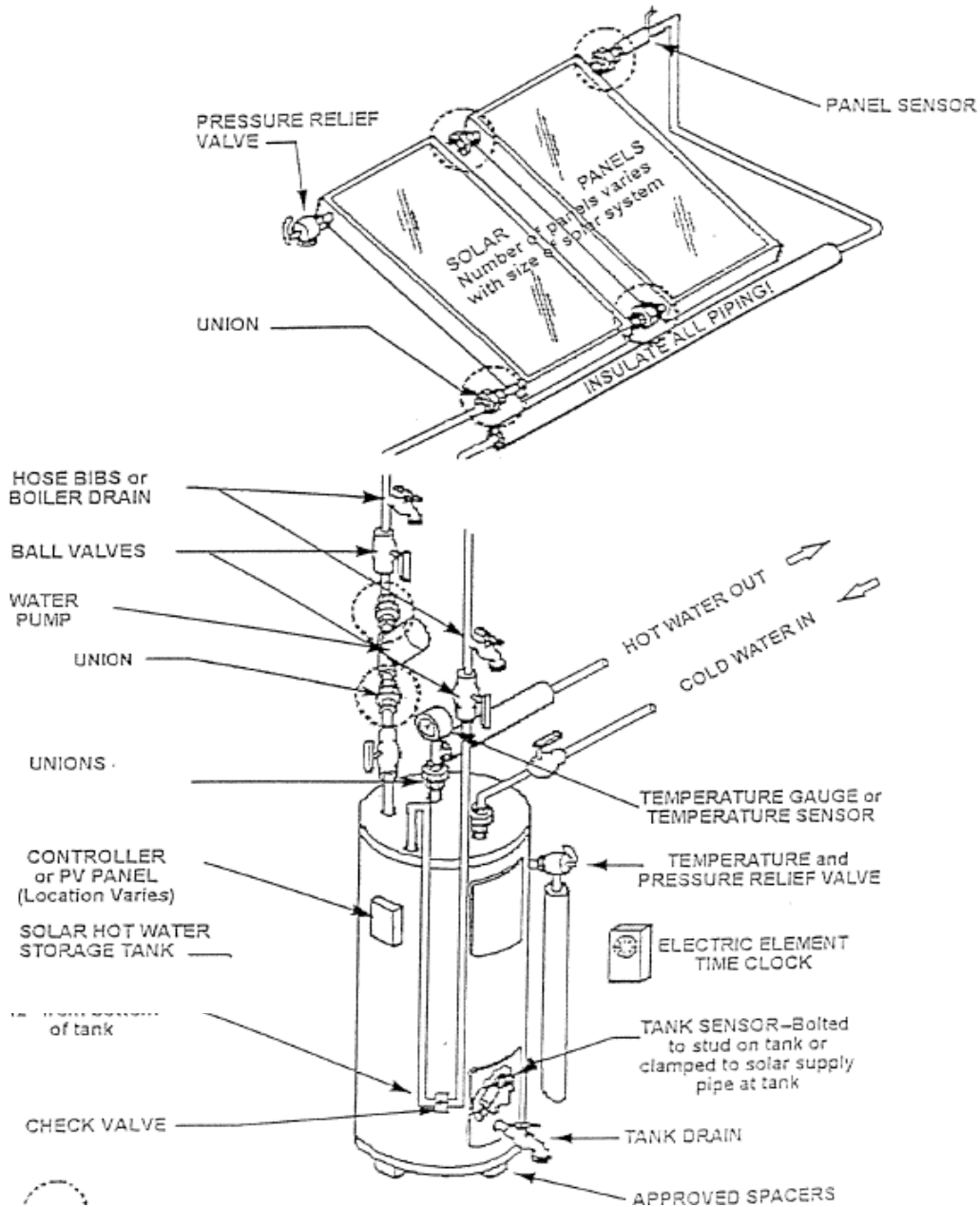

Figure 3: Top-Return Residential Forced Circulation System Design. Source: Hawaiian Electric Company



7 Basic SWH System Sizing Equations

65 Gallon System

Tank Capacity	65 gallons
Temperature Rise	55° F (130 – 75 = 55°F)
Weight of Water	8.33 lbs/gal
Energy to Raise 1 lb of water 1°F	1 BTU
Energy to Heat 65 gal to 130°F	29,780 BTU/day (see Table 2)

	BTU/day (from Table 2)	Solar Fraction
Collector Output	26,802	90%
	29,780	100%
	32,758	110%

80 Gallon System

Tank Capacity	80 gallons
Temperature Rise	55° F (130 – 75 = 55°F)
Weight of Water	8.33 lbs/gal
Energy to Raise 1 lb of water 1°F	1 BTU
Energy to Heat 80 gal to 130°F	36,652 BTU/day (see Table 2)

	BTU/day (from Table 2)	Solar Fraction
Collector Output	32,987	90%
	36,652	100%
	40,317	110%



120 Gallon System

Tank Capacity	120 gallons
Temperature Rise	55° F (130 – 75 = 55° F)
Weight of Water	8.33 lbs/gal
Energy to Raise 1 lb of water 1°F	1 BTU
Energy to Heat 120 gal to 130°F	54,978 BTU/day (see Table 2)

Collector Output	BTU/day (from Table 2)	Solar Fraction
	49,480	90%
	54,978	100%
	60,476	110%



Solar Water Heating Design Guidelines

8 Form 1 - Residential System Verification Form

Customer: _____ Work Order #: _____
 Contractor: _____ Centralized Dual System: Yes / No
 Phone: _____ Collector Access: One Story / Two Story / Other
 Contact: _____ Tank Access: Locked / Unlocked
 Subcontractor(s) Used: Yes / No If YES, Name & Lic. #: _____
 Location of Installation: Oahu / Molokai / Lanai / Maui / Hawaii

SYSTEM DATA								Accepted	Denied	
1	Installation Reason	Burnout / Retrofit								
2	Previous Water Heater Type	Electric / Heat Pump / Solar / None								
3	System Type	Active / Passive								
4	Neighborhood / Community									
5	Sunshine Zone	300	350	400	450	480	500	550		
6	Collector Manufacturer									
7	Collector Model No.									
8	Collector Size	3' x 7'	3' x 8'	4' x 6'	4' x 8'	4' x 10'				
9	Absorber Coating	chrome / paint								
10	Collector Orientation	degrees (true)								
11	Collector Orientation Factor	% derating								
12	Collector Mounting Method	flush / side tilt / end tilt								
13	Collector Tilt	degrees								
14	Collector Tilt Factor	% derating								
15	Actual Hot Water Storage	gallons								
16	Back-Up Heating Type	Electric / Gas / Heat Pump								
17	Pump Type	AC / DC / None								
18	System Solar Fraction	%								

SIZING: HOT WATER STORAGE

		Gal. / Day	Line
▶ Hot Water Use:	For Owner Occupied – # of Residents _____ x 20 gal./day, or	_____	1
	For Rental or Military – # of Bedrooms _____ (see Storage in Table 1)	_____	2
▶ Bathing Adjustment:	Total # of Additional Showers / Day _____ x 10 gal./day	_____	3
	Total # of Baths / Week _____ x 20 gal. ÷ 7 days	_____	4
▶ Laundry Adjustment:	Hot or Warm Water – # of Loads / Week _____ x 18 gal. ÷ 7 days	_____	5
▶ Required Storage (add Lines 1 through 5, or from Table 1, whichever is greater)		<input type="text"/>	6
▶ Actual System Storage Selected (from Table 2)			
	Gallons	Daily BTU Requirement	
Tank #1	_____	_____	7
Tank #2	_____	_____	8
Tank #3	_____	_____	9
▶ Total Actual System Storage: (add Lines 7, 8 and 9)	<input type="text"/>	<input type="text"/>	10

SIZING: SOLAR COLLECTOR(S)

		BTU / Day Output	Line
▶ BTU/Day Output for Solar Collector(s) (from Table 6)	Model 1: _____	Model 2: _____	11
▶ # of Collectors per Model	Model 1: _____	Model 2: _____	12
▶ Sub-Total: Collector BTU/Day Output (multiply Lines 11 and 12)	Model 1: _____	Model 2: _____	13
▶ Total Collector BTU/Day Output (add Model 1 and Model 2 from Line 13)		<input type="text"/>	14
▶ Derating BTU Output/Day: Orientation _____°; Factor _____% (from Chart 1) x Line 14		_____	15
Tilt _____°; Factor _____% (from Table 3) x Line 14		_____	16
▶ Adjusted Collector BTU/Day Output (Subtract Lines 15 and 16 from Line 14)		<input type="text"/>	17

SOLAR FRACTION

▶ Percent Solar Fraction (Divide Line 17 by Line 10) _____ % 18

Inspector: _____	Customer Present: _____	Date: ____ / ____ / ____	Form 1: Accepted / Denied
------------------	-------------------------	--------------------------	---------------------------



9 System Inspection Checklist

Hawai'i Energy Efficiency Program's Water Heating System Inspection Check List

Customer		Contractor		Authorization No.		
Name		<input type="checkbox"/> Post <input type="checkbox"/> Re <input type="checkbox"/> Other		Authorization No.		
Address		<input type="checkbox"/> Received <input type="checkbox"/> Not Received <input type="checkbox"/> Undetermined		Inspection number 1 / 2 / 3 / 4 / 5 / 6		
Line	Description	Requirement	Accepted	Denied	Section	
1	Collector Exposure	unshaded			1.09	
2	Multiple Collector Connection Method	parallel			1.04	
3	Collector Mounting Brackets	manuf / num / seal / fast / secure			2.04/3.02.2	
4	Collector Leg Sets	manuf / brace / fast / secure			2.05/3.02.4	
5	Collector Support Structure	non-corr / spacing / fast / secure			2.06/3.02.5	
6	Support Structure Anchoring	num / location / freq / secure			2.19/3.02.5	
7	Collector Sensor Attachment	clamp / seal / tape / location			3.04	
8	Clearance From Roof	collector / support structure			3.02/3.02.5	
9	Collector Pressure Relief Valve	Watts 3L / other			2.01	
10	Roof Penetration Sealed	piping / elec / fasteners			3.09	
11	Roof Sealing Method	/ / /			3.09	
12	Roof Piping	supports / adhered / freq / bends			3.07	
13	Roof Piping Insulation	UV protected			3.08	
14	PV Make / Model / Wire Size	/ /			2.01/3.06	
15	Collector Mounting Method	lag / lag w/cup / hanger / rod / other			2.06/2.19/3.02	
16	Tank #1 Make / Model / Age	/ /			2.01	
17	Tank #2 Make / Model / Age	/ /			2.01	
18	Optional Equipment	Circ OTD Mix Temp. Exp. Tank other			2.23	
19	Multiple Tank Connection Method	series / check valve / location			1.04/3.03.1	
20	Tank Cover Plates / Warning Labels	accessible / visible			3.03	
21	Tank Heat Loop	12" / secure			3.03	
22	Tank Sensor Connection	clamp / seal / tape / stud / location			3.04	
23	Tank Thermostat Setting	120 deg. F / 50 deg. C			3.03	
24	Tank Support	slab / bricks /shims stable / EQ strap			3.03.1	
25	Tank TPR	100XL NCLX HT575 other / tight			2.01/3.01	
26	Tank Overflow Line	attached / tight			3.03	
27	Pump Heliodyne Pack	Grundfos Laing 809 Taco other			2.01/3.03	
28	Controller Heliodyne	DTT 84 94 GL30-LGO 0301U / access			2.01/3.04	
29	Controller Setting	automatic			3.04	
30	Time Switch	EH-40 WH-40 other / access			2.01/3.05	
31	Time Switch Settings	on off on off			3.05	
32	Temperature Gauge / Temp.	Pasco Winters 0301U other / access			2.01	
33	Plumbing Material	piping / fittings / valves / caps			2.13 - 2.17	
34	Isolation Valve Type	ball / iso/flare / other			2.16.1	
35	Isolation Valve Location	CWL / LSSL / USSL / SRL			3.07	
36	Check Valve	swing / horizontal / location			2.16.2/3.03.1	
37	Pipe supports	material / frequency / location			2.15/3.07	
38	Fastening Hardware	stainless steel			2.19	
39	Piping Insulation	SSL / SRL / HWL / CWL / overflowline			2.20/3.08	
40	Wall / Ceiling Penetrations	Pipe / wire			3.09	
41	Insulation Joints	sealed / butted / packed			3.08	
42	System Design Type	Top / Side / Bottom / Multi / Passive			1.04	
43	Overall Installation / Equipment	workmanlike / protected			3.01	
44	System Design Type	operational			3.01	
45	Inspection Results	System			1.03	
Line	Comments	Inspection Date / Time	Inspector			
For Office Use Only:						
Leak at:			Annual Maintenance Sticker <input type="checkbox"/> Yes <input type="checkbox"/> No			
<input type="checkbox"/> Yes <input type="checkbox"/> No -- Picked up <input type="checkbox"/> Energy Scout <input type="checkbox"/> Timer -- <input type="checkbox"/> Partial <input type="checkbox"/> Full Waive: <input type="checkbox"/> No Access <input type="checkbox"/> Multiple Stories						

Version Sept. 23, 2011 Checklist



11 Accepted Products List (APL)

ACCEPTED PRODUCTS LIST

IMPORTANT NOTE: *Hawaii Energy does not and cannot endorse or warrant any vendor, manufacturer, product, installation and/or maintenance. The list below may not be the most comprehensive or current information available.*

COLLECTORS

APL list for Collectors is the same as current Table 6 collectors. Please reference Table 6.

STORAGE TANKS & HEATERS

Manufacturer	Brand Name	Model No.	Type	Heating Element
A.O. Smith	AO Smith	SUN 65	Open Storage	Yes
	ProMax	SUN-80	Open Storage	Yes
		SUN-120	Open Storage	Yes
	A'O Smith	SBU 1201OTS	Open Storage	Yes
	A'O Smith	SBV 82 1OTS	Open Storage	Yes
American	Solar Storage Tanks	SE62-65H-045S	Open Storage	Yes
		SE62-80H-045S	Open Storage	Yes
		SE62-119R-045S	Open Storage	Yes
Bradford White	Solar Saver	MS65R6 (SS)	Open Storage	Yes
		MS80R6 (SS)	Open Storage	Yes
		MS120R6 (SS)	Open Storage	Yes
Lochinvar Corp	SunSaver	FTA066-K	Open Storage	Yes
		FTA-082-K	Open Storage	Yes
		FTA-120-K	Open Storage	Yes
Rheem	Solaraide	81VR80-1	Open Storage	Yes
		81VR120-1	Open Storage	Yes
Richmond	Solar Model	S80-1	Open Storage	Yes
		S120-1	Open Storage	Yes
		S80TC-1	Open Storage	Yes
		S120TC-1	Open Storage	Yes



STORAGE TANKS & HEATERS (cont'd)

Manufacturer	Manufacturer	Manufacturer	Manufacturer	Manufacturer
Ruud	Marathon	MTS85245	Open Storage	Yes
		MTS105245	Open Storage	Yes
	Solar Servant	RSPER80-1	Open Storage	Yes
		RSPER120-1	Open Storage	Yes
		RSPER80-T	Open Storage	No
		RSPER120-T	Open Storage	No
	Solar Servant TC	RSTCR80-1	Open Storage	Yes
		RSTCR120-1	Open Storage	Yes
		RSTCR80-T	Open Storage	No
		RSTCR120-T	Open Storage	No
Solahart Industries	Solahart	150 J	Closed Storage	Yes
		180 J	Closed Storage	Yes
		220 J	Closed Storage	Yes
		300 J	Closed Storage	Yes
		440 J	Closed Storage	Yes
		150 K	Closed Storage	Yes
		180 K	Closed Storage	Yes
		220 K	Closed Storage	Yes
		300 K	Closed Storage	Yes
		440 K	Closed Storage	Yes
		180KF	Closed Storage	Yes
		220KF	Closed Storage	Yes
		440KF	Closed Storage	Yes
		150 KBCXII	Closed Storage	Yes
		180 KBCXII	Closed Storage	Yes
		220 KBCXII	Closed Storage	Yes
		300 KBCXII	Closed Storage	Yes
		440 KBCXII	Closed Storage	Yes
		150 L	Open Storage	Yes
		180 L	Open Storage	Yes
		220 L	Open Storage	Yes
		300 L	Open Storage	Yes
		440 L	Open Storage	Yes
		150 LX	Open Storage	Yes
		180 LX	Open Storage	Yes
		220 LX	Open Storage	Yes
		300 LX	Open Storage	Yes
		440 LX	Open Storage	Yes
		440 L	Open Storage	Yes



Manufacturer	Brand Name	Model No.	Type	Heating Element
Solahart Industries (cont'd)	Solarhart	252 SL	Open Storage	Yes
		303 SL	Open Storage	Yes
		270SL2USA	Closed Storage	Yes
		340SL4USA	Closed Storage	Yes
		430SL4USA	Closed Storage	Yes
Solar Edwards	Edwards	DES125 (42 gal.)	Open Storage	Yes
		DES250 (80 gal.)	Open Storage	Yes
		DES 350 (92 gal.)	Open Storage	Yes
		L180 (48 gal.)	Open Storage	Yes
		L305 (80 gal.)	Open Storage	Yes
		L440 (116 gal.)	Open Storage	Yes
State Industries	State	SBV-66-10TS	Open Storage	Yes
		SBV-82-10TS	Open Storage	Yes
		OST-66-E	Open Storage	Yes
		OST-80-E	Open Storage	Yes
		OST-120-E	Open Storage	Yes
SunEarth	SunEarth	SE65-6, -12	Open Storage	Yes
		SE80-6, -12	Open Storage	Yes
		SE120-6, -12	Open Storage	Yes
		SU80-1	Open Storage	Yes
		SU120-1	Open Storage	Yes
		SU80U-1	Open Storage	Yes
		SU120U-1	Open Storage	Yes



TIME SWITCHES

Manufacturer	Brand Name	Model No.	Type
BRK Electronics Inc.	BRK Electronics	TS212	AC
		TS212M	AC
	First Alert	TS212R	AC
		TS212RP	AC
Intermatic Inc.	Intermatic	WH40	AC
		EH10	AC
		EH40	AC
		T104	AC
	Grasslin	GM40AV	AC
		WHQ4	AC
M.H. Rhodes	Marktime	72133 AB	AC
NSi	Tork	E103B	AC
Paragon Electric		EC-4005	AC
Solahart	Solar Optimiser	TEK 414	DC
		TEK 415	AC
Tork	Tork	EW103B	AC



12 APL Inclusion Request

Please fully complete this form to request product introduction to the Hawai'i Energy APL:

Submitting CEA/Distributor:		Date Submitted:	
Contact Person:		Contact Phone:	
Contact Email:		Fax:	
Product Name:			
Mode Number:	Manufacturer:		
Description:	Product Website:		

place "X" in appropriate column box below

Supporting Documentation Submitted:		Yes	No	N/A
1	Product Cut Sheet (marketing flyer)	<input type="checkbox"/>	<input type="checkbox"/>	<input type="checkbox"/>
2	Product Specification Sheet(s)	<input type="checkbox"/>	<input type="checkbox"/>	<input type="checkbox"/>
3	Product Certification(s)	<input type="checkbox"/>	<input type="checkbox"/>	<input type="checkbox"/>
4	Product Warranty Statement	<input type="checkbox"/>	<input type="checkbox"/>	<input type="checkbox"/>
5	Equipment Test Data/Approval	<input type="checkbox"/>	<input type="checkbox"/>	<input type="checkbox"/>
6	Installation Instructions	<input type="checkbox"/>	<input type="checkbox"/>	<input type="checkbox"/>

Additional Comments/Notes:

**** For Office Use Only ****

Determination: Accepted Denied Incomplete

Reviewed By: _____ Date: _____

Comments:

APPENDIX A

RESIDENTIAL SOLAR WATER HEATING PROGRAM RULES

Updated: December 2017

General Information: The Hawai'i Public Utilities Commission has contracted with Leidos Engineering, LLC to administer the Hawai'i Energy program. Hawai'i Energy is the ratepayer-funded energy conservation and efficiency program serving the islands of Hawai'i, Lāna'i, Maui, Moloka'i and O'ahu. Throughout this Appendix A any reference to "Hawai'i Energy" shall mean Leidos Engineering, LLC as an administrator to the Hawai'i Public Utilities Commission. This appendix comprises the "Rules" for the Residential Solar Water Heating Program ("SWH Program" or "Program").

1. Application to become a Hawai'i Energy Participating Contractor. Solar Water Heating contractors interested in participating in Hawai'i Energy's SWH Program are required to do the following:
 - a. Submit a completed Solar Water Heating Program Application ("Participation Application").
 - b. Provide an e-mail address as the primary means of communication with Hawai'i Energy.
 - c. Submit proof of all required insurances outlined in Sections 8 and 9 of the Rules.
 - d. Attend an orientation meeting, which will be required as a prerequisite to participation in the SWH Program; and
 - e. Comply with all SWH Program Rules (Appendix A), Program Standards and Specifications (Solar Water Heating Handbook), Branding Guidelines (Appendix B) and other requirements established by Hawai'i Energy from time-to-time for participation.

The Participation Application will be evaluated by Hawai'i Energy and the applicant will be notified in writing if it is accepted as a Solar Water Heating Participating Contractor ("Participant" or "Participating Contractor"). Contractor participation shall begin only after Hawai'i Energy issues notice of acceptance ("Notice of Acceptance"). Then, Participant will be added to Hawai'i Energy's online Participating Contractor's List.

2. SWH Program Subject to Modification. Hawai'i Energy reserves the right to modify all appendices to the Participation Application and other requirements at any time without notice with or without cause. Hawai'i Energy will provide Participant with advance written notice to the extent possible.
3. General Information.
 - a. Scope of Work: Participants in Hawai'i Energy's SWH Program furnish all labor, tools, materials, equipment, meals, lodging, transportation and supervision necessary to meet the SWH Program requirements in a workmanlike manner deemed by Hawai'i Energy to be of sufficient quality and service to satisfy both Hawai'i Energy and the electric utility customer ("Customer"). Participants must conform to all Participation Application

appendices and other requirements established by Hawai'i Energy, as well as any modifications that may from time to time be established by Hawai'i Energy.

- b. Term: The term of participation will start on the date of Hawai'i Energy's acceptance of Participant into the SWH Program and end on the Program Year end-date on the Participation Application. Hawai'i Energy in its sole discretion may extend the term for up to an additional twelve (12) months by providing written notice to the Participant at least thirty (30) days prior to expiration of the term.
- a. Non-exclusivity: There are multiple Participants in the SWH Program. No exclusive grant of work shall be made to any one Participant. Hawai'i Energy does not endorse any particular market provider, trade ally, manufacturer, product, laborer, or system design by offering this Program.
- c. Work Standards: For each qualifying installation, Participant submits the SWH rebate application ("Rebate Application") and other supporting documentation that may be required. Each Hawai'i Energy-approved SWH installation (the "Work") must be done in a manner that complies with (a) all applicable codes and ordinances, (b) the warranty of the manufacturer or distributor of the equipment and materials used in connection with the Work, (c) Rules here (d) Program Standards and Specifications (Solar Water Heating Handbook) and (e) other requirements established by Hawai'i Energy.

4. Contractor Eligibility and Requirements.

- a. Eligibility. Participant eligibility is determined by satisfaction of all the following criteria. Participant must:
 - i. Possess a current and active contractor's license issued by the State of Hawai'i.
 - a. Contractors must possess at least one of the following licenses to be eligible: A, B; C-13; C-37; C-60; C-61; C-61a
 - ii. Furnish Hawai'i Energy with a signed and completed Participation Application; and
 - iii. Prior to acceptance into the Program:
 - a. Provide updated Certificates of Insurance within 30 days of expiration or any changes to applicable insurance policies.
 - b. Provide system schematic(s) and collector/system roof mounting method drawings for each system design type; and
 - c. Complete an in-person Program orientation. Neighbor island orientations will be held via conference call.
- b. Contractor Approval. Contractors satisfying eligibility requirements and furnishing required documentation can participate in the SWH Program subject to compliance with all appendices and modifications if any.
 - i. Contractor must attend an orientation meeting prior to final approval as a SWH Program Participating Contactor and issuance of a Notice of Acceptance by Hawai'i Energy.

- ii. Contractor participation in the Program begins only after Hawai'i Energy issues a Notice of Acceptance.
 - iii. Participants will be added to the Hawai'i Energy online Clean Energy Ally list.
 - c. Continuing as a Participating Contractor. In order to maintain status as a Participant the following is required:
 - i. Complete no less than three (3) Hawai'i Energy-approved installations per program year.
 - ii. Update and maintain all required licenses and insurance requirements; and
 - iii. Have a designated representative attend at least one (1) contractor meeting per program year.
5. Customer Eligibility Requirements.
- a. Customers must be ratepayers of the Hawaiian Electric Companies (islands of O'ahu , Hawai'i, Maui, Moloka'i, and Lāna'i) for at least six (6) months, and the account holder must be shown on the Rebate Application. Ratepayers from other islands or areas do not qualify for Hawai'i Energy offerings.
 - b. Customer's dwelling must be occupied year-round as a primary domestic residence.
 - c. Customer must complete and sign a Hawai'i Energy Rebate Application form.
 - d. Customer system must be installed with Hawai'i Energy Accepted Products (See: Solar Water Heating Handbook) by a Participating Contractor.
 - e. Customers with newly constructed homes are not eligible for SWH Program participation.
6. System Eligibility Requirements.
- a. The solar water heating system must replace either an existing electric water heater, an electric heat pump water heater, or an existing solar water heating system that is at the end of its useful life (burnout) and has an electric backup.
 - b. Burnout systems that previously received a Program rebate need to be fifteen (15) years or older. Exceptions may be given by Hawai'i Energy in any one of the following circumstances:
 - i. Warranty for both collectors (10 yrs.) and tank (6 years) have expired, and the system is beyond reasonable repair.
 - ii. Homes have sustained damage due to abnormal circumstances (e.g., fire, natural disaster, etc.).
 - iii. Recently purchased home where a previous rebate was issued to a previous owner and the system was neglected beyond repair and is in need of replacement.
 - iv. Homes have sustained major renovations preventing previous system re-installation; or
 - v. The system possesses a health or safety hazard to the current residents and is in need of emergency replacement.

- vi. Recently purchased homes with existing systems that are inadequate to the new homeowner's needs. For example, a recently purchased home with an 80-gallon tank and five (5) or more current residents.
- c. Existing gas water heaters or an existing solar water heater with a gas backup are not eligible for SWH Program participation.

7. Rebate Application Processing, Installation & Inspections.

a. Work Order Authorization.

- i. For each Rebate Application, a Hawai'i Energy-issued rebate work order ("W/O") number is required prior to system installation. Allow at least three (3) business days for W/O issuance for systems that require a pre-inspection or have complications.
- ii. Participants must have the account holder's full name, address, Contract ID, installation date, and sunshine zone available to receive a work order.
- iii. Rebate W/Os will be issued on a first-come first-served basis based on the availability of funds for the program year.
- iv. Rebate W/O numbers may not be issued if Participant's license, insurance, or other contractor documents are expired or void. See Section 8 for more detail.
- v. Hawai'i Energy may require a pre-inspection prior to system installation. Multiple rebate systems and systems requiring an exception will be inspected.
- vi. W/Os will expire thirty (30) days from Hawai'i Energy's issuance. All W/Os may be extended an additional 30 days at the request of the Participant at sole discretion of Hawai'i Energy.
- vii. Installation of any system prior to W/O authorization may result in \$100 penalty (See Section 13).
- viii. Work orders are only eligible for payment if they are received within thirty (30) days of installation. Work orders received after thirty (30) days of installation will be returned to the Contractor and the rebate will be forfeited.

- b. System Installation: Once the W/O is received the system must be installed to Hawai'i Energy specifications. See Program Standards & Specifications (Solar Water Heating Handbook) for system specific details. For Solar Interest Buy Down ("SIBD") systems, please inform Hawai'i Energy upon completion of installation so we may inform the Lender to release payment. Also, please inform Customers that a Hawai'i Energy inspection may be performed.

c. Post Installation.

- i. Within thirty (30) days of system installation, Participants shall submit post-installation documentation to Hawai'i Energy to include:
 - a. Signed and dated Rebate Application
 - b. Sizing Form (Form 1)
 - c. Invoice showing rebate was given (unless SIBD system)
 - d. Permit or permit application documentation
 - e. Photographs showing the installed collector(s), tank(s) and timer(s) as requested.
- ii. Post-installation documentation must be mailed to:

Hawai'i Energy
Solar Water Heating Program
P.O. Box 3920
Honolulu, HI 96812

- iii. Failure to submit required documentation within thirty (30) days may result in a \$100 penalty fee or rebate payment cancellation (See Section 13).
- d. Rebate Application: Participants are responsible for ensuring that Rebate Application(s) are filled out accurately, completely, and legibly. Rebate Applications are subject to change without notice at any time with or without cause at Hawai'i Energy's sole discretion.
 - i. Incomplete Rebate Applications will be returned to the Participant for corrections and will not be processed.
 - ii. Rebate Applications must be corrected and returned within ten (10) business days from receipt of notification, failure to do so may result in a \$100 penalty (See Section 13).
 - iii. All applicable information: including system cost and rebate amount, shall be filled in prior to submission for Customer's signature.
 - iv. Customer's relationship to the electric utility account holder must be identified if the Customer is not the account holder.
 - v. Rebate Application pricing amounts must be consistent with the submitted invoice copy.
- e. System Inspection.
 - i. Hawai'i Energy will inspect and verify system's compliance with the Program Standards and Specifications (Solar Water Heating Handbook), including use of Hawai'i Energy Accepted Products, workmanship, and system sizing. Please see system sizing in the Solar Water Heating Handbook for further details.
 - ii. Hawai'i Energy reserves the rights to modify inspection frequency and requirements without notice at any time with or without cause.
- f. Failed Inspections: Participants will be notified if a system failed inspection by fax or email.
 - i. Participant shall correct and notify the Program of corrected system deficiencies within thirty (30) days of receiving first system denial notification.
 - ii. If more than one (1) inspection is required, failed deficiencies must be corrected within fifteen (15) days of notification. Systems requiring more than one re-inspection for the same denial may be assessed a re-inspection penalty of \$100.
- g. Rebate Payment Processing: Hawai'i Energy will process Rebate Applications payments (less any applicable penalties) for Participants for systems that have been accepted and paperwork is complete.
 - i. Allow 6-8 weeks for payment processing after Hawai'i Energy has received your completed paperwork.

- ii. If penalties apply, they will be deducted from the rebate amount owed to the Participant. If the penalty or penalties occurred after payment, they will be deducted from a future rebate. Please see Section 13 for penalty details.
- iii. In addition to penalties already in place, a supplemental penalty structure could be adopted if more than one of the following conditions are present during any one of four quarterly reviews:
 - Contractor (or a representative) has not attended at least one (1) Trade Ally Meeting in the previous Calendar Year.
 - Contractor has Customer complaints that have not been addressed and/or have not been resolved.
 - Greater than three (3) late paperwork submissions in a quarter.
 - Re-use or installation of existing system components without prior Program approval.
 - Sizing a system between an 80-89% solar fraction without prior Program review and approval.
 - Failure to update expired insurance for two (2) or more quarters.
 - Overall lack of quality in either workmanship or interaction(s) with the Program or Customers.

8. Insurance Requirements: Participant and anyone acting under its direction or control or on its behalf shall at its own expense procure and maintain in full force at all times during the period of performance of these terms:

- a. Commercial General Liability Insurance with bodily injury and property damage combined single limit of at least ONE MILLION DOLLARS (\$1,000,000) per occurrence.
- b. Automobile Liability Insurance with at least FIVE HUNDRED THOUSAND DOLLARS (\$500,000) per occurrence for the following:
 - i. Bodily-injury and
 - ii. Property damage liability.
- c. Workers Compensation, Temporary Disability, and other similar insurance required by state and federal laws.

9. Insurance Exceptions and Details.

- a. Worker's Compensation Insurance Exemption. Participants conducting business and operating as sole proprietors are exempt from carrying Worker's Compensation insurance pursuant to Act 196 from the 2011 Hawai'i State legislative session as enacted into Hawai'i Revised Statutes 386-1. It is the Participant's sole responsibility to comply with any and all laws that may require otherwise.
- b. Waiver of Subrogation. Participant and anyone acting under its direction or control or on its behalf hereby waives and will cause its insurers to waive all rights of subrogation which Participant or its insurers may have against Leidos Engineering, LLC/Hawai'i Energy.

- c. Hawai'i Energy & Leidos Engineering, LLC as Additional Insured. Insurance policies (except Workers Compensation and Temporary Disability) providing the insurance coverage required in this Article will name Hawai'i Energy & Leidos Engineering, LLC as an additional insured. Coverage must be primary in respect to the additional insured. Any other insurance carried by Leidos Engineering, LLC will be excess only and not contribute with this insurance.
 - d. Excess or Umbrella Coverage. Lower primary limits are acceptable if the excess or umbrella coverage includes the provisions required by Hawai'i Energy and the total coverage meets or exceeds the required minimum limits.
 - e. Certificates of Insurance. Participant's Designated representative shall file with Hawai'i Energy or designee certificates of insurance certifying that each of the foregoing insurance coverages are in force prior to acceptance into the Program, and further providing that Hawai'i Energy will be given thirty (30) days written notice of any material change in, cancellation of, or intent not to renew any of the policies. Receipt of any certificate showing less coverage than requested is not a waiver of the Participant's obligation to fulfill the requirements.
10. Indemnification: Participant will indemnify, defend and hold harmless Hawai'i Energy, Leidos Engineering, LLC, the State of Hawai'i and its directors, officers, employees, contractors and agents (collectively, "Indemnified Parties") from and against claims of any kind, including reasonable attorneys' fees and costs, or legal suits arising out of or related to Participant's participation and/or Work for the SWH Program, unless the claims or suits are caused solely by the action or inaction of the Indemnified Parties. In no event shall any of the Indemnified Parties be liable for any punitive, exemplary, special, indirect, incidental, or consequential damages (including, but not limited to, lost profits, lost business opportunities, loss of use or equipment down time, and loss of or corruption to data) arising out of or relating to the SWH Program, regardless of the legal theory under which such damages are sought.
11. Status of Participant.
- a. Independent contractor: Participant will act solely as an independent contractor in performing installations on behalf of Participant's Customers and will not act or hold itself out as Hawai'i Energy's agent, servant, partner, or joint venturer for any purpose. All employees of Participant or anyone acting on its behalf will work under the supervision of Participant and will not act or hold themselves out as Hawai'i Energy's agents, servants, partners, or joint venturers for any purpose. Participant has the sole responsibility to employ and pay such workers as may be required to perform the Work, use appropriate equipment, follow good work practices, and provide appropriate supervision.
 - b. No Representations or Warranties from Hawai'i Energy. Participant understands and agrees that Hawai'i Energy is not liable for any representation or warranty made by Participant to Customers concerning quality or performance of materials or workmanship. Participant further understands and agrees that Hawai'i Energy makes

no warranties concerning performance, materials, and installation, express or implied, INCLUDING WARRANTIES OF MERCHANTABILITY OR FITNESS FOR A PARTICULAR PURPOSE. Participant shall make no statements, representations or claims to Customers inconsistent with this section.

- c. Pre-Approval Needed for Subcontracting or Assignment. Participant shall not assign nor subcontract any portion of the Work under the SWH Program without first submitting the name and contractor's license number of the proposed subcontractor for assignment to Hawai'i Energy and receiving written consent from Hawai'i Energy to subcontract or assign, which consent may be granted or withheld in Hawai'i Energy's sole discretion. Any attempt to assign or subcontract Participant's participation, in whole or in part, without obtaining the prior written consent of Hawai'i Energy shall result in Participant's immediate termination from the SWH Program.

A request to subcontract or assign must contain the name and location of individuals or firms to whom Work will be transferred and information on the qualifications and experience of those individuals or firms to perform the transferred Work. Participant shall ensure that the terms and conditions contained herein and any amendment hereto regarding the Work to be performed are incorporated into and attached to any subcontract or assignment.

Participant shall indemnify and hold the Indemnified Parties harmless from any loss caused by a failure of Participant to comply with the provisions of this Section. Hawai'i Energy's consent to subcontracting or assignment shall not relieve Participant of responsibility for the performance of the Work in accordance with these terms and conditions and any amendments thereto.

12. Laws and Regulations.

- a. Compliance: Participant shall comply with federal, state, and local statutes, regulations and public ordinances of any nature governing the Work and the standards for materials or mechanics of installation, including without limitation, those statutes specifically referred to in this Section 12. In addition, Participant, at its expense, shall obtain any and all licenses and permits required for the Work. Failure to obtain and maintain required permits and licenses, and failure to comply with all applicable laws and regulations, shall be cause for termination from the Program. Participant shall indemnify and defend Indemnified Parties from any liability, fines, damages, costs, or expenses arising from Participant's failure to comply with this section. Nothing in these terms shall impose upon Hawai'i Energy a duty to obtain or inspect for work permits or other required license. Participant shall notify Hawai'i Energy when any permit or license, or the insurance required, is revoked, modified, or not renewed.
- b. Taxes: Participant assumes exclusive liability for all contributions, taxes or payments required to be made because of persons hired, employed, or paid by Participant by the federal and state Unemployment Compensation Act, Social Security Acts, and all

amendments, and by all other current or future acts, federal or state, requiring payment by the Participant on account of the person hired, employed, or paid by Participant for Work performed under the Program. All sales, use and excise taxes applicable to the value or use of any property incorporated, furnished, or otherwise supplied by Participant are included in the price or rates. Participant assumes exclusive liability for all such taxes charged or chargeable upon any such goods or materials supplied by Participant pursuant to the terms herein.

Participant must submit to Hawai'i Energy all payee information and the IRS Form W-9 at the beginning of every calendar year for processing of the IRS Form 1099. It is understood that Hawai'i Energy will forward a copy of the IRS Form 1099 to the payee at the end of the calendar year.

- c. **Safety and Health Regulations:** Participant shall comply with all federal, state, and local laws and regulations pertaining to health, safety, sanitary facilities, and waste disposal. Participant shall meet all requirements of the Occupational Safety and Health Act of 1970 (OSHA) including all amendments. Participant shall also comply with any standards, rules, regulations, and orders promulgated under OSHA and particularly with the agreement for State development and enforcement of Occupational Health and Safety Standards as authorized by Section 18 of the Act.

13. Penalties.

- a. **Rebate Penalties:** Penalties of \$100.00 each may be assessed to rebate payments for non-compliance. Multiple penalties can apply to the same rebate. Penalties may be deducted from rebates for one or all of the following scenarios:
 - i. Installation of a system prior to work order authorization;
 - ii. Failure to submit completed Rebate Application, Sizing Form, Invoice, and Permit documentation within thirty (30) days of installation;
 - iii. Failure to submit corrected paperwork within ten (10) business days of receipt of notification;
 - iv. Failure to correct system denial within thirty (30) days of receipt of notification;or
 - v. Excessive inspections: more than one re-inspection needed per denial.
- b. **Compliance Related Penalty Schedule:** When a Participant fails to comply with Program Rules, the penalty schedule below will be enacted and escalate in sequence until the behavior is corrected:
 - i. A meeting (or conference call for Neighbor Island Participants) will be held to outline Program requirements and expectations;
 - ii. A courtesy letter will be sent to the Participant requiring the behavior be corrected, and outlining corrective actions;
 - iii. The Participant will be removed from Fast Track status (if applicable);

- iv. The Participant will be placed on probation for a period of three (3) months in which all work orders will be assessed a \$100.00 penalty;
 - v. The Participant will be denied new work order authorizations and suspended from program participation for three (3) months; and finally
 - vi. The Participant will be terminated from the Program.
- c. Hawai'i Energy reserves the right to pursue any and all remedies in addition to penalties in these Rules to the extent allowed by law or in equity.
14. Termination for Cause: In addition to termination due to violation of Program Rules, a Participant can also be terminated if any of the following conditions occur during the period of performance of these Terms. Termination is at Hawai'i Energy's sole discretion.
- a. Participant fails or is unable to perform its obligations under the terms of the Program, including without limitation adherence to the Program Rules, and other specifications, policies and/or procedures established by Hawai'i Energy;
 - b. Participant becomes involved in a labor problem, which in the opinion of Hawai'i Energy unacceptably impedes or slows down the Work;
 - c. Participant fails to commence correction of defective work immediately after notification of defect and to continuously and vigorously pursue correction of defect until the Work is completed to Hawai'i Energy's satisfaction;
 - d. Participant and/or any of its subcontractors, agents, partners, or joint venturers has a mechanic's or materialman's lien filed against it in connection with the work performed in this program;
 - e. Participant makes a general assignment for the benefit of its creditors;
 - f. Participant has a receiver appointed because of insolvency; or
 - g. Participant files bankruptcy or has a petition for involuntary bankruptcy filed against it.

Upon Hawai'i Energy's termination of Participant from the SWH Program for cause, Hawai'i Energy may secure such substitute Work as it deems necessary to complete the Work. In the event Hawai'i Energy acquires substitute Work under this provision, Participant agrees to pay Hawai'i Energy upon demand, the difference between what the substitute Work actually costs Hawai'i Energy and what Participant would have been paid had it completed the Work itself. Hawai'i Energy shall have the right to set off the cost of permits, insurance, or licenses that Participant failed to obtain, against any moneys owed to Participant by Hawai'i Energy. Hawai'i Energy may refuse to honor any Rebate Applications(s) submitted by Participant for payment. Participant remains solely liable for all work performed in connection with the Program.

15. Termination For Convenience: Hawai'i Energy has the right to terminate the Participant from the Program at any time for convenience by giving written notice of such to Participant.
16. Branding Guidelines for Public-Facing Materials: If Participant produces public-facing materials referencing or incorporating Hawai'i Energy's name and logo, it must conform with Hawai'i Energy branding Guidelines (see Appendix B). For more information, please contact the Hawai'i Energy

Marketing & Communications Department at HawaiiEnergy@leidos.com.

- a. Participant's use of the Approved Language and/or Logo shall continue only if the Term of the Participation Application, and upon expiration or termination of the Participant from the Program for any reason, Participant shall promptly discontinue all use of the Approved Language and/or Logo unless otherwise modified by Hawai'i Energy.
- b. Participant's descriptions and characterizations of its participation in the Program shall conform in all respects to Application appendices and other requirements established by Hawai'i Energy.
- c. If Participant is terminated from the SWH Program for any reason, Participant shall promptly cease to represent itself as a participant in the Program.
- d. If a Participant violates the Branding Guidelines, they may be subject to three (3) month suspension from the Hawai'i Energy website Participating Contractor listing and any Hawai'i Energy advertisements.

17. Ownership of Materials, Information, Copyrights and Discoveries.

- a. Ownership of Materials. Except as otherwise provided, any and all drawings, specifications, technical information and business information of any type whatsoever, whether or not characterized as secret or confidential obtained under the Program or related to the Work, whether received or disclosed by written or oral communication or otherwise, including all documents, materials, and information prepared or developed by Participant in the performance of the Program (except as provided below), are the exclusive property of Hawai'i Energy and shall be deemed Hawai'i Energy's confidential information and the Participant shall receive and maintain the same in the strictest confidence. Participant shall not use such materials or information for any purpose other than for purposes of quotation or performance under the Program and shall not otherwise disclose such materials or information to others except with Hawai'i Energy's consent given in writing.
- b. Use of Intellectual Property. Participant shall have no right to use any trademark, trade name, copyright, logo, or other intellectual property owned by Hawai'i Energy, (collectively, "Intellectual Property") for any purpose, except as provided herein.
- c. Excluded Materials and Information. Participant is not obligated to maintain in confidence any information that is now generally known in the industry or was previously in Participant's possession or custody and not obtained from Hawai'i Energy, or received from third parties, as evidenced by satisfactorily dated and authenticated documentary evidence.

18. Other Provisions.

- a. Access to Records: Upon request, Participant shall make available for inspection and audit by Hawai'i Energy or its designee any and all records and/or documents relating to Work performed under the Program for a period of up to five (5) years from the

completion of the Work under the Program. Participant must provide reasonable access to the related documentation and data requested.

- b. **Regulatory Approvals:** These terms shall be contingent upon any and all required governmental and regulatory approvals, including those of the Public Utilities Commission.
- c. **New Technologies:** New technologies may be eligible for Residential Solar Water Heating Program Rebates only after they have received a written notice of approval from Hawai'i Energy. Participants who are interested in integrating a new technology into the Program must submit a Standards & Specifications Change Request form found in the Standards and Specifications (Solar Water Heating Handbook). All approvals must be granted prior to the installation or implementation of the technology if a Rebate is to be given.
- d. **Publicity:** Hawai'i Energy reserves the right to publicize Participant's participation in the Program for promotional and reporting purposes unless Participant submits a written request to the Program requesting anonymity.
- e. **Force Majeure:** The term "Force Majeure" as used here shall mean any cause beyond the control of the party affected, and which by reasonable efforts the party affected is unable to overcome, including without limitation the following: acts of God; fire, flood, landslide, lightning, earthquake, hurricane, tornado, storm, freeze, volcanic eruption or drought; blight, famine, epidemic or quarantine; strike, lockout or other labor difficulty act or failure to act of the other party; theft; casualty; war; invasion; civil disturbance; explosion; acts of public enemies; or sabotage. Notwithstanding any other terms contained herein to the contrary, neither party shall be liable or responsible for failure to carry out any of its obligations under the Program caused by Force Majeure. A party rendered unable to fulfill any obligation under this the Program by reason of Force Majeure shall make reasonable efforts to remove such inability in the shortest possible time, and the other party shall be excused from performance of its obligations until the party relying on Force Majeure shall again be in full compliance with its obligations under the Program.
- f. **Patents and Copyrights:** Participant agrees that in performing Work under the Program, it will not use any process, program, design, device, or material which infringes on any United States patent or copyright or any trade secret agreement. Participant agrees to indemnify, defend, and hold harmless Indemnified Parties from and against all losses, damages, claims, fees, and costs, including but not limited to reasonable attorneys' fees and costs, arising from or incidental to any suit or proceeding brought against any of the Indemnified Parties for patent, copyright or trade secret infringement arising out of Participant's Work. Hawai'i Energy shall promptly notify Participant of any such suit or proceeding and shall assist Participant in defending the action by providing any necessary information.
- g. **Severability of Provisions:** In the event a court or other tribunal of competent jurisdiction at any time holds that any provision of these terms are invalid, the

remainder of the terms shall not be affected thereby and shall continue in full force and effect.

- h. Entire Agreement: Should the applicant be accepted as a Participant, the entire agreement (“Entire Agreement”) between Participant and Hawai‘i Energy consists of requirements in the Application (including appendices), Hawai‘i Energy’s issuance of a Notice of Acceptance, SWH Program Rebate Applications, invoices and any and all documents as identified and/or requested by Hawai‘i Energy from time to time.
- i. No Entity Deemed a Drafter; Hawai‘i Law Governs: Neither Participant nor Indemnified Parties will be deemed a drafter of any or all of the Entire Agreement. As such, any interpretation rule against the drafter does not apply. Applicant and Hawai‘i Energy agree that the laws of the State of Hawai‘i will govern any disputes, claims and/or issues related to the SWH Program including the Application and appendices, as well as modifications and related documents, without regard to rules governing the conflict of laws.
- j. No Waiver: The failure at any time of either party to enforce any of the provisions contained herein, or to require at any time performance by the other party of any of the provisions hereof, shall in no way be construed to be a waiver of such provisions, nor in any way construed to affect the validity of these terms or any part hereof, or the right of any party thereafter to enforce each and every such provision.
- k. Headings Not Controlling: Headings in these Rules are for reference purposes only.

APPENDIX B

Hawai'i Energy CEA Brand Guide

HAWAII ENERGY

Brand Guidelines

For Clean Energy Allies



For Program Year 2021

BRAND GUIDELINES

0	Introduction	2	Design Elements
1	Messaging	2.1	Logo
1.1	Brand Promise	2.1.1	Logo & Wordmark
1.2	Brand Pyramid	2.1.2	Primary Logo: Horizontal
1.3	Approved Messaging and Text References	2.1.3	Primary Logo: Vertical Other
1.4	Applications for Logo and Messaging	2.1.4	Logo Variations
1.5	Right to Audit	2.1.5	Logo Usage
		2.1.6	CEA Logo
		2.2	Colors

SECTION 0

Introduction

The Hawai'i Energy graphic identity standards provide a foundation for clear and consistent communication of the brand's identity. Adhering to common standards ensures that the brand's communication is clear and consistent throughout all applications.

All mediums—publications, websites, advertising, signage, letterhead, or business cards—layout, color, and typography are orchestrated to impart a unified “signature.” This publication includes a description of the new logo and guidelines for its use including official colors and typefaces, as well as the appropriate use of the brand logo.

SECTION 1

Messaging

Our brand is more than a name or a logo. The brand is the overall feeling that an audience attaches to our communication efforts, our locations, and our customer experience.

1.1

**HAWAI'I ENERGY'S
BRAND PROMISE**

At the heart of every brand platform is the brand promise.

It's WHY we do WHAT we do for our target audiences.

Also, for internal use only, and is the benchmark by which all communications moving forward should be measured.

We promise to get
Hawai'i on the fast track
to 100% clean energy.

1.2

THE BRAND PYRAMID

This is the Hawai'i Energy Core Messaging Pyramid. It's typical of the kinds of conversations you'll probably have with friends, family, and business associates.

When you tell the story successfully, your partners and friends will understand the core mission and be able to describe Hawai'i Energy in their own words.

Start simple:

Hawai'i Energy promises to get Hawai'i on the fast track to 100% clean energy.

Begin to tell the story:

Hawai'i Energy makes it *easy* for everyone in Hawai'i to play their part in the clean energy movement.

Give them reasons to believe:

Hawai'i Energy educates island families and businesses about the many, lasting benefits of clean energy.

Hawai'i Energy encourages and rewards practical, everyday energy-saving decisions.

Hawai'i Energy can save money, grow our economy, and reduce the demand for electricity and foreign imports.

1.3

APPROVED MESSAGING AND TEXT REFERENCES

In text, Clean Energy Allies may choose from the following approved messaging to describe themselves:

- A Clean Energy Ally of the Hawai'i Energy Program
- [COMPANY NAME] is a Clean Energy Ally of the Hawai'i Energy Program
- We are a Clean Energy Ally of the Hawai'i Energy Program
- Clean Energy Allies extend the reach of the Hawai'i Energy Program by helping to deliver energy-saving incentives, education, and other direct Program benefits to electric customers.

DO NOT use the following phrases to describe yourself:

- Partner with/Partner of the Hawai'i Energy Program
- Selected by/Awarded by the Hawai'i Energy Program

1.4

PRACTICAL APPLICATIONS FOR LOGO AND MESSAGING USAGE

The Hawai'i Energy Approved Messaging and Logo:

1. Can only be used or displayed when it is accompanied by the clear identification of the Clean Energy Ally and only in the following circumstances:
 - a) In flyers, brochures or retractable paid advertisements that appear in broadcast or print media, such as newspapers and magazines, circulated either to the public at-large or to trade organizations or similar groups;
 - b) In displays used for presentations in trade shows; and
 - c) On the Clean Energy Ally's website.

2. Must NOT be used or displayed:
 - a) In the pages of any non-retractable directory (e.g., telephone books);
 - b) On any business or identification cards, letterheads, printed forms, or other materials used by the Clean Energy Ally UNLESS provided advanced written approval by Hawai'i Energy;
 - c) On any vehicle used by the Clean Energy Ally or its employees, agents or contractors UNLESS provided advanced written approval by Hawai'i Energy; or
 - d) On the clothing of its employees, agents, or subcontractors; or
 - e) In a way that would mislead or tend to mislead anyone as to the nature of its relationship with Hawai'i Energy or would represent or tend to represent the Clean Energy Ally as an employee, agent, partner, joint venture, affiliate or representative of Hawai'i Energy;
 - f) As an incorporation of the Clean Energy Ally's corporate or commercial name or into any trademark, service mark, trade name or logo.

1.5

RIGHT TO AUDIT

Hawai'i Energy may periodically perform random audits of the Clean Energy Ally's materials to ensure compliance with these requirements. If an item is selected for review, Hawai'i Energy will contact you directly. In the event of non-compliance with regards to the use of the Approved Messaging and Logo or if it is deemed by Hawai'i Energy that its Approved Messaging and Logo is misused, the Clean Energy Ally must immediately retract all references to Hawai'i Energy at the Clean Energy Ally's cost. Further, Hawai'i Energy reserves the right at its sole discretion to take other actions as necessary.

SECTION 2

Design Elements

These are the tools that help build our brand. Used consistently, these elements will strengthen the communication, understanding and impact of the brand.

2.1

HAWAI'I ENERGY'S LOGO & WORDMARK

Hawai'i Energy's graphic identity program was launched in October of 2009, with the introduction of a new name (Hawai'i Energy) and graphic identity (logo and wordmark). The graphic identity combines the positive outlook of Hawai'i Energy and its commitment to improving energy awareness. The identity forms the foundation upon which the entire graphic identity program is built.

The identity program is designed to be flexible enough to meet Hawai'i Energy's need to reach all audiences, while creating a strong brand presence in Hawaii's communities. Hawai'i Energy's use of the identity guidelines is integral to building public awareness and support for its mission.

The signature artwork is available to download in several file formats and color versions. Please do not alter the signature artwork or colors. Designated Pantone® color is for stationery and business card and other spot color applications. See Pantone® guide for accurate color match.



Hawai'i Energy

2.1.1

LOGO & WORDMARK

Hawai'i Energy has two primary identifiers—the brand's logo and the brand's wordmark. Each identifier uses the brand's full name **Hawai'i Energy**. The logo or wordmark should appear on all Hawai'i Energy affiliated applications.

Hawai'i Energy's logo consists of the wordmark plus its symbol. The logo can appear in one of two ways—horizontal or stacked. The logo should be treated as one unit. The proportion and spacing of the elements should not be altered in anyway. If you have a usage where you would like to use the symbol alone, please request permission from Wall-to-Wall Studios.



Icon



Type



Type

Icon

Space
(Width of the "H")

2.1.2

**PRIMARY LOGO:
HORIZONTAL**

Hawai'i Energy's logo has two different versions, a simple blue Pluggy icon for white backgrounds and instances where the logo is printed in a limited number of colors. As well, a more detailed white version of the Pluggy icon can be used on colored background when there is ample contrast.

The horizontal version of the logo should be used when space demands.



White Background



Colored Background

2.1.3

PRIMARY LOGO: VERTICAL

Hawai'i Energy's logo has two different versions, a simple blue Pluggy icon for white backgrounds and instances where the logo is printed in a limited number of colors. As well, a more detailed white version of the Pluggy icon can be used on colored background when there is ample contrast.

The vertical version of the logo should be used when space demands.



Hawai'i Energy

White Background



Hawai'i Energy

Colored Background

2.1.4

OTHER LOGO VARIATIONS

Hawai'i Energy's wordmark consists of the brand's full name. It should also be treated as one unit. The proportion and spacing of the elements should not be altered in any way. The wordmark is typeset in Kievit and should not be set in any other typeface.

For publications using 2+ colors, the colors should be Hawai'i Energy Blue, and Black.

For 1 color applications, Black should be used.

Wordmark: The wordmark should always appear in either Hawai'i Energy Blue or Black.



Hawai'i Energy

Wordmark - White Background



Hawai'i Energy

Wordmark - Dark Background



Hawai'i Energy

Two Color Logo - White Background



Hawai'i Energy

Two Color Logo - Dark Background



Hawai'i Energy

One Color Logo - White Background



Hawai'i Energy

One Color Logo - Dark Background

2.1.5

LOGO USAGE

Logo: The official logo colors are Hawai'i Energy Blue (PMS 306 C), Medium Grey (PMS Cool Grey 7) and Black. These colors should be used in all applications of the logo. For 4-color publications, the CMYK conversion should be used for its colors. For screen/web applications, the RGB conversion should be used.

The supporting colors were developed for usage on marketing materials that require a larger family of colors to complement the primary colors.

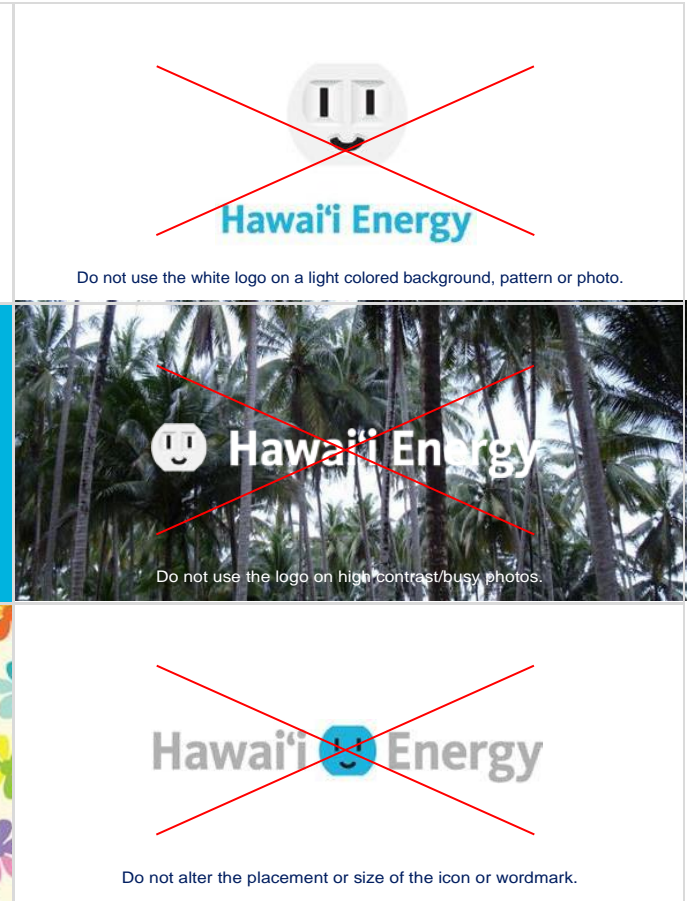
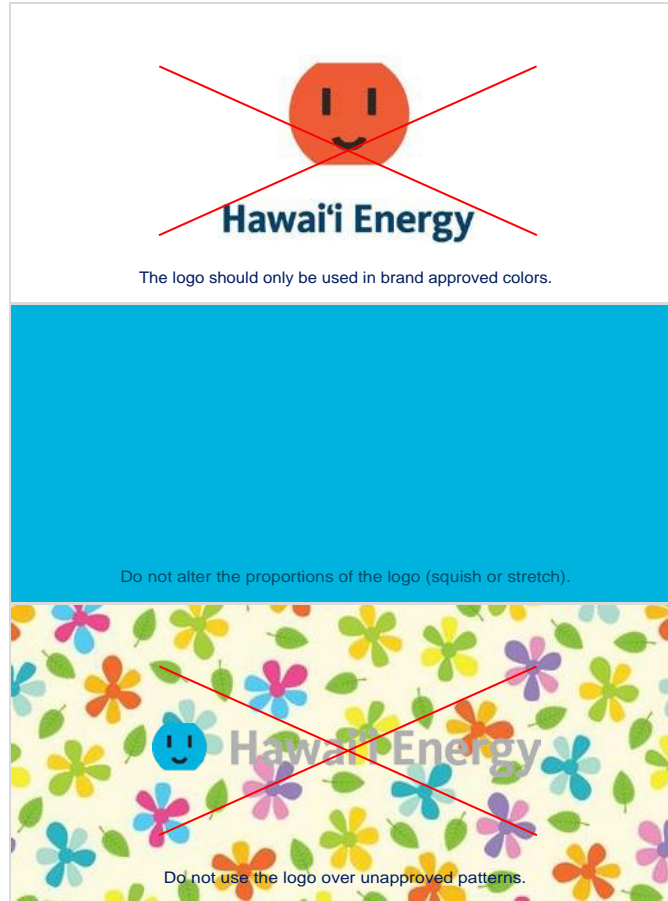

2.1.6

CLEAN ENERGY ALLY LOGO

You may use the Hawai'i Energy Clean Energy Ally logo in lieu of the Hawai'i Energy logo in your marketing efforts. Choose from either the black and white or color logo. Upon request to hawaiienergy@leidos.com, the logo will be provided to you in JPG format. If you need the logo in another format, please specify.

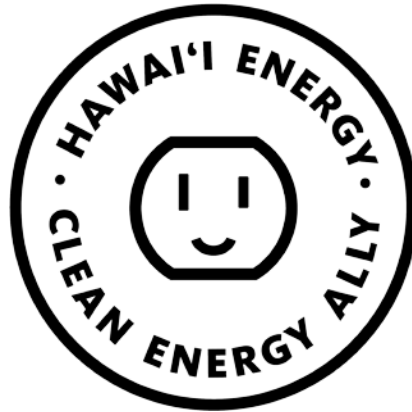

2.2

BRAND COLORS

Logo: The official logo colors are Hawai'i Energy Blue (PMS 306 C), Medium Grey (PMS Cool Grey 7) and Black. These colors should be used in all applications of the logo. For 4-color publications, the CMYK conversion should be used for its colors. For screen/web applications, the RGB conversion should be used.

The supporting colors were developed for usage on marketing materials that require a larger family of colors to complement the primary colors.

Primary Brand Colors

HAWAI'I ENERGY BLUE
PMS 306
C:72 M:7 Y:5 K:0
R:0 G:179 B:223
#00B3DF



MEDIUM GREY
PMS Cool Grey 7
C:0 M:0 Y:0 K:37
R:174 G:176B:178
#AEB0B2



DARK BLUE
PMS 3025
C:100 M:27 Y:18 K:56
R:0 G:76 B:102
#004C66



ELECTRIC YELLOW
PMS 393
C:6 M:0 Y:55 K:0
R:244 G:240 B:144
#F4F090



BLACK
PMS Black
C:30 M:30 Y:30 K:100
R:0 G:0 B:0
#000000



LIGHT GREY
PMS Cool Grey 1
C:4 M:2 Y:4 K:8
R:223 G:225B:223
#DFE1DF

Supporting Brand Colors

Mahalo.

For questions regarding use of brand elements, please contact:



Wall-To-Wall Studios

1128 Nu'uanu Avenue, Suite 203

Honolulu, HI 96817

808.566.0880

www.walltowall.com